

YE82-160Q

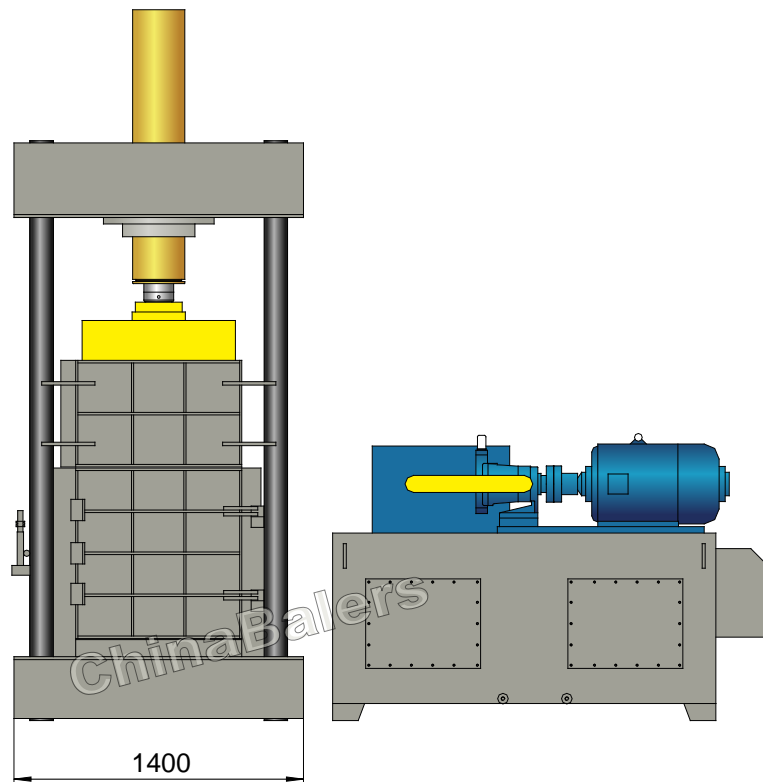

YE82-160Q

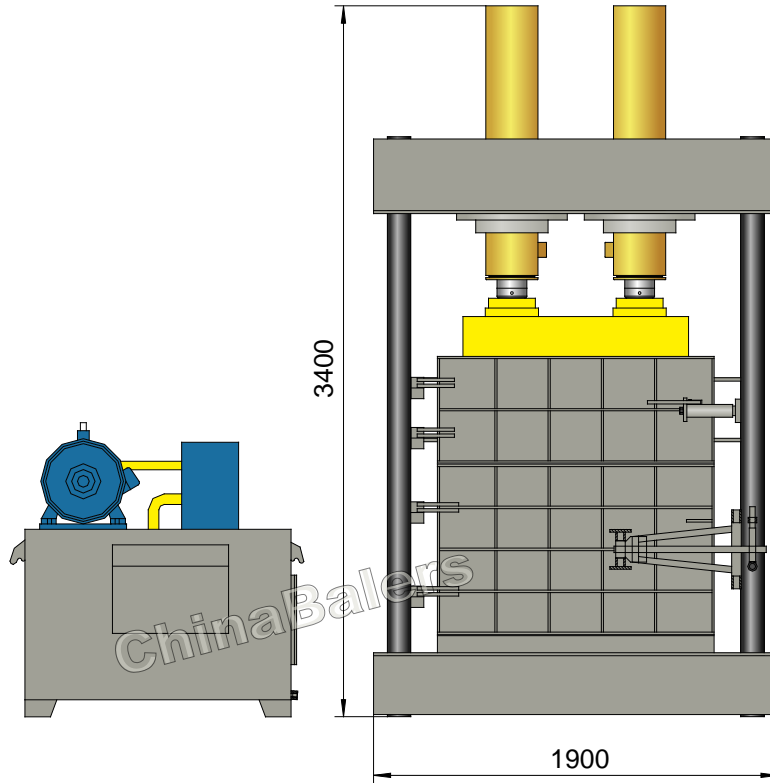

Vertical Metal Baler

Model: YE82-160Q

Power System (Motor)

Type: Y200L2-6
 Rated Power: 22 kW
 Rated Speed: 970 rpm
 Power Spec: 3PH, 50 / 60Hz

System Parameters

Main Pressure Cyl. Force: 2×80 Ton
 Hydraulic System Pressure: 25 MPa

Hydraulic System (Pump)

Type: 160YCY14-1B
 Rated Displacement: 160 ml/r
 Max Operating Pressure: 31.5 MPa

Standard Configuration

NOK (JAPAN) Seal Packings for Cylinders;
 Mn16 Steel Liners, Thickness 8mm;
 Cooler; Magnetic Oil Filter.

Operation System

Manual Valve Operation

General Description

Main Machine Size (L×W×H): 1900×1400×3400 mm
 Press Box Size (L×W×H): 1100×760×1200 mm
 Space Between Ram & Bottom: Max. 1200 mm; Min. 300 mm
 Bale Size (L×W): 1100×760 mm
 Bale Weight (Copper Wire): 800-1000 kg
 Production Rate (Copper Wire): 4.0-5.0 tons/hr
 Strapping: 5 Steel Strips, 2-way, Manual Strapping.
 Bale Discharging: Manual Discharging
 Shipping Weight: Approx. 7 tons
 Loading (Standard Containers): 1×20'GP

Hydraulic Oil Brand

Oil Tank Volume: 960 ltr

ISO VG	China	U.S.		Britain	France
	GB11118.1	CALTEX CO.	MOBIL	SHELL	ELF CO.
HM 46	46 #	Rando HD46	D.T.E46	Tellus 46	Elfolna 46
HM 68	68 #	Rando HD68	D.T.E68	Tellus 68	Elfolna 68

Above information are indicative not engaging. Rights reserved for change if necessary.