

YE82-100FB

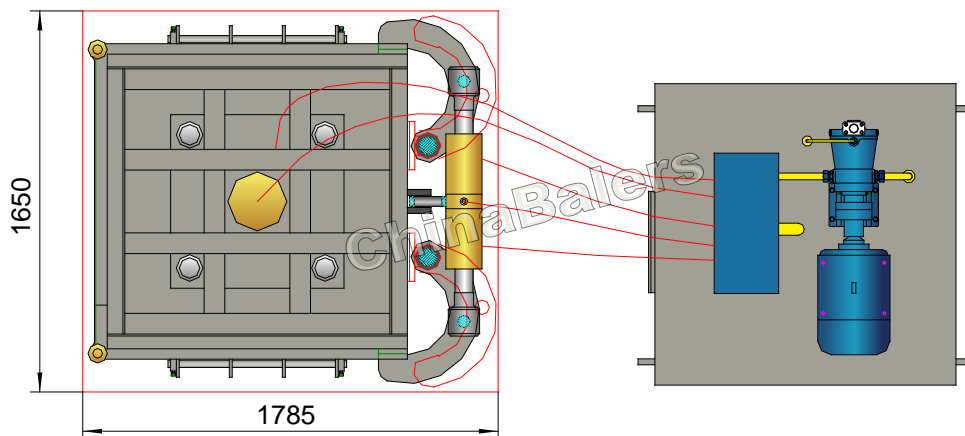

YE82-100FB

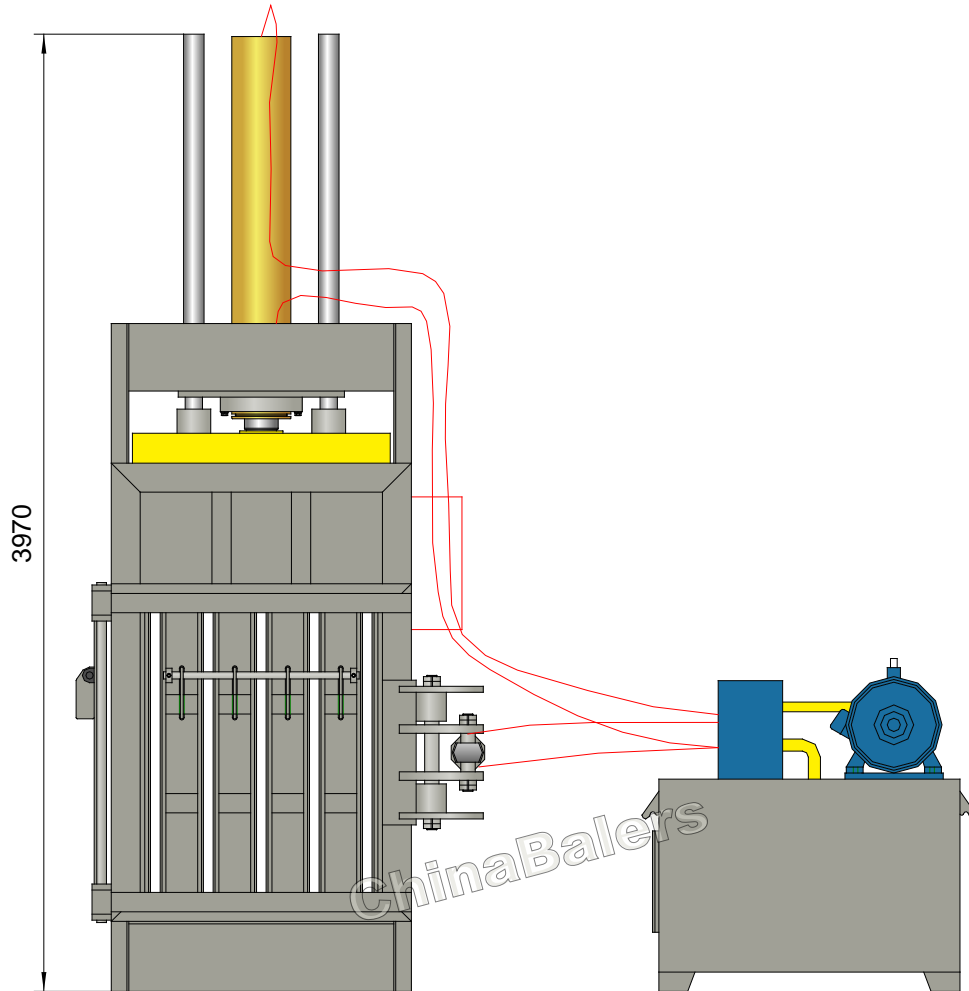

Vertical Cardboard Baler

Model: YE82-100FB

Power System (Motor)

Type: Y180M-4
 Rated Power: 18.5 kW
 Rated Speed: 1470 rpm
 Power Spec: 3PH, 50 / 60Hz

System Parameters

Main Pressure Cyl. Force: 100 Ton
 Locking Cyl. Force: 24 Ton
 Hydraulic System Pressure: 25 MPa

Hydraulic System (Pump)

Type: 80YCY14-1B
 Rated Displacement: 80 ml/r
 Max Operating Pressure: 31.5 MPa

Standard Configuration

NOK (JAPAN) Seal Packings for Cylinders.

Operation System

Hydro-electrical Valves, Push Button Control.

General Description

Main Machine Size (L×W×H): 1785×1650×3970 mm
 Press Box Size (L×W×H): 1100×1100×1600 mm
 Space Between Ram & Bottom: Max. 1600 mm; Min. 400 mm
 Bale Size (L×W): 1100×1100 mm
 Bale Weight (Cardboard): 350-500 kg
 Production Rate (Cardboard): 1000-1500 kg/hr
 Strapping: Tempered Iron Wire, ϕ 2.8/3.2mm, 5 Lines, Manual Strapping.
 Bale Discharging: Turn-out at Returning Stroke
 Shipping Weight: Approx. 6.8 tons
 Loading (Standard Containers): 1×20'GP

Hydraulic Oil Brand

Oil Tank Volume: 750 ltr

ISO VG	China	U.S.		Britain	France
	GB11118.1	CALTEX CO.	MOBIL	SHELL	ELF CO.
HM 46	46 #	Rando HD46	D.T.E46	Tellus 46	Elfolna 46
HM 68	68 #	Rando HD68	D.T.E68	Tellus 68	Elfolna 68

Above information are indicative not engaging. Rights reserved for change if necessary.