

Y81T-125A

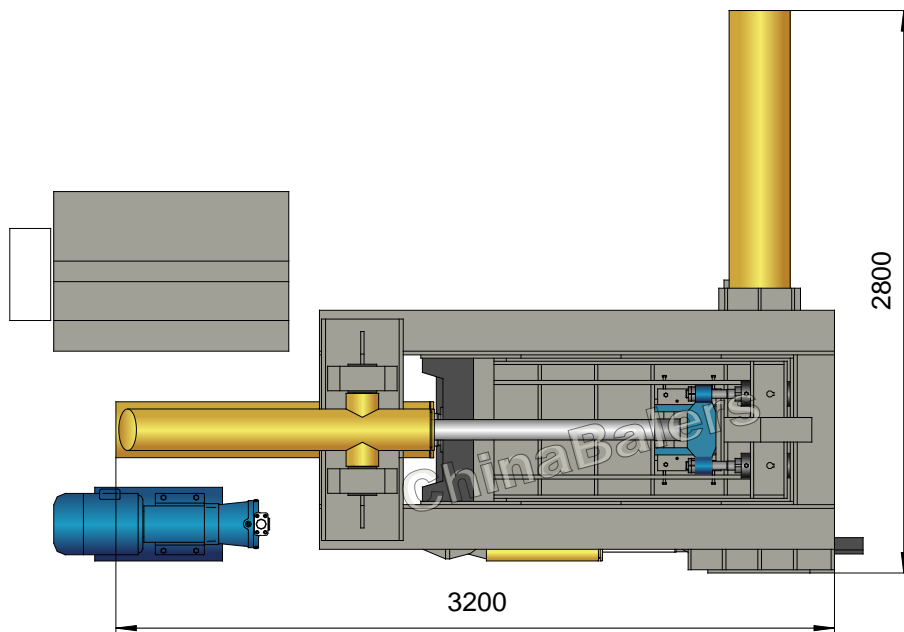

Y81T-125A

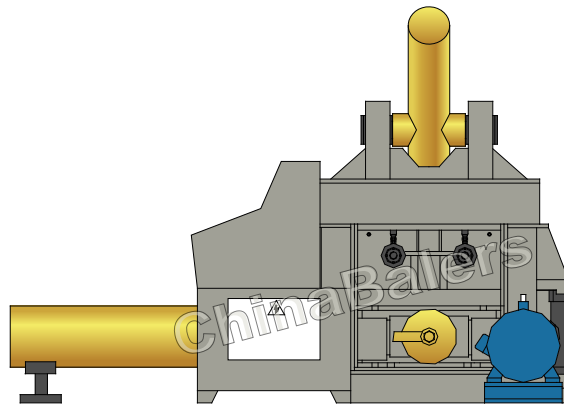
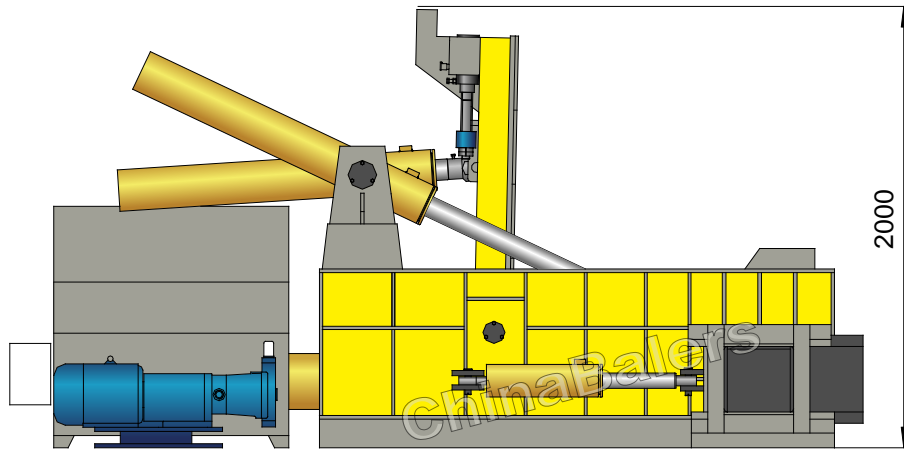
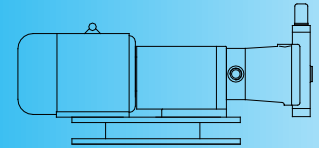

Steel Shavings Baler

Model: Y81T-125A

Power System (Motor)

Type:	Y180M-4
Rated Power:	18.5 kW
Rated Speed:	1470 rpm
Power Spec:	3PH, 50 / 60Hz

Hydraulic System (Pump)

Type:	80YCY14-1B
Rated Displacement:	80 ml/r
Max Operating Pressure:	31.5 MPa

Operation System (Optional)

- Option 1: Manual Valve Operation
- Option 2: PLC Operation

System Parameters

Lid Cyl. Force:	50 Ton
Side Pressure Cyl. Force:	100 Ton
Main Pressure Cyl. Force:	125 Ton
Small Door Cyl. Force:	32 Ton
Hydraulic System Pressure:	25 MPa
Idle Cycle Time:	Approx. 90 Sec

Standard Configuration

A3 Steel Liners, Surface Heat Treatment.

Optional Configuration

- Cutting Blades & Teeth (2 sides);
- Loading Hopper; Cooler / Heater;
- Diesel / Diesel Generator for Power.

General Description

Main Machine Size (L×W×H):	3200×2800×2000 mm
Press Box Size (L×W×H):	1200×700×600 mm
Bale Size (W×H):	240×240 mm
Bale Weight (Steel Shavings):	Approx. 40 kg
Production Rate (Steel Shavings):	Approx. 1.0 tons/hr
Shipping Weight:	Approx. 6.5 tons
Loading (Standard Containers):	

Hydraulic Oil Brand

Oil Tank Volume: 600 ltr

ISO VG	China	U.S.		Britain	France
	GB11118.1	CALTEX CO.	MOBIL	SHELL	ELF CO.
HM 46	46 #	Rando HD46	D.T.E46	Tellus 46	Elfolna 46
HM 68	68 #	Rando HD68	D.T.E68	Tellus 68	Elfolna 68

Above information are indicative not engaging. Rights reserved for change if necessary.