

# YDJ-500

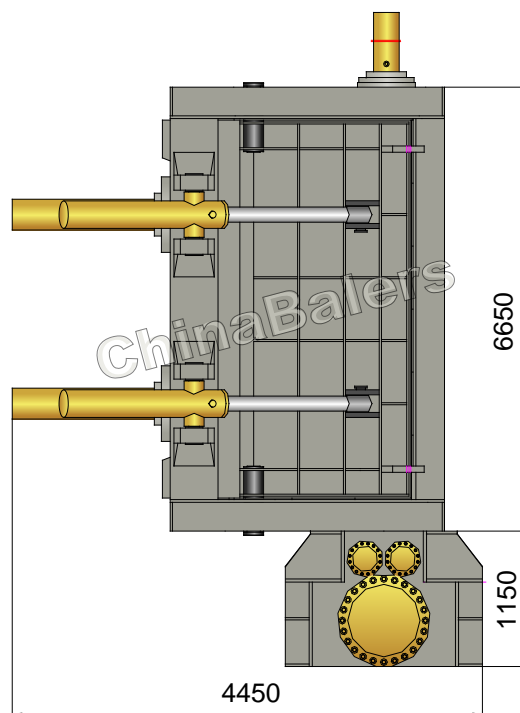

# YDJ-500

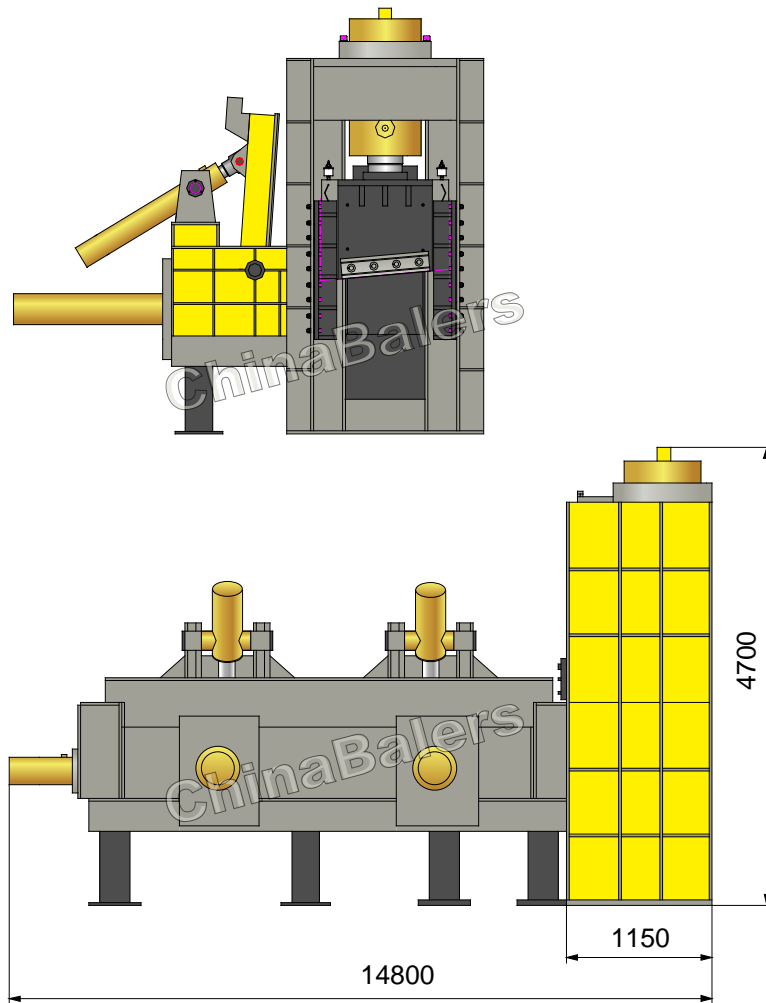

## Shear Baler

Model: YDJ-500

### Power System (Motor, 2 sets)

Type:	Y280S-4
Rated Power:	75 kW
Rated Speed:	1470 rpm
Power Spec:	3PH, 50 / 60Hz

### Hydraulic System (Pump, 4 sets)

Type:	160YCY14-1B
Rated Displacement:	160 ml/r (/set)
Max Operating Pressure:	31.5 MPa

### Standard Configuration

A3 Steel Liners, Surface Heat Treatment;  
NOK (JAPAN) Seal Packings for Cylinders;  
Cooler / Heater; Magnetic Oil Filter.

### System Parameters

Shear Cyl. Force:	500 Ton
Stamper Cyl. Force:	2×56 Ton
Lid Cyl. Force:	3×38.5 Ton
Side Pressure Cyl. Force:	3×75 Ton
Pushing Cyl. Force:	50 Ton
Hydraulic System Pressure:	28 / 25 MPa
Cutting Speed:	3-4 times/min

### Operation System (Optional)

Option 1: Manual Valve Operation  
Option 2: PLC Operation

### Optional Configuration

#45 Steel Liners; Loading Hopper;  
Diesel / Diesel Generator for Power.

### General Description

Main Machine Size (L×W×H):	14800×4450×4700 mm
Press Box Size (L×W×H):	6000×1500×800 mm
Bale Size (L×W×H):	6000×500×500 mm
Stamper Size (L×W):	450×600 mm
Blade Width & Angle:	700 mm; 5 Degree
Production Rate (Steel):	4.0-7.0 tons/hr
Space Required:	≦20000×7000 mm
Shipping Weight:	
Loading (Standard Containers):	

### Hydraulic Oil Brand

### Oil Tank Volume:

ISO VG	China	U.S.		Britain	France
	GB11118.1	CALTEX CO.	MOBIL	SHELL	ELF CO.
HM 46	46 #	Rando HD46	D.T.E46	Tellus 46	Elfolna 46
HM 68	68 #	Rando HD68	D.T.E68	Tellus 68	Elfolna 68

Above information are indicative not engaging. Rights reserved for change if necessary.