

Q43-5000A

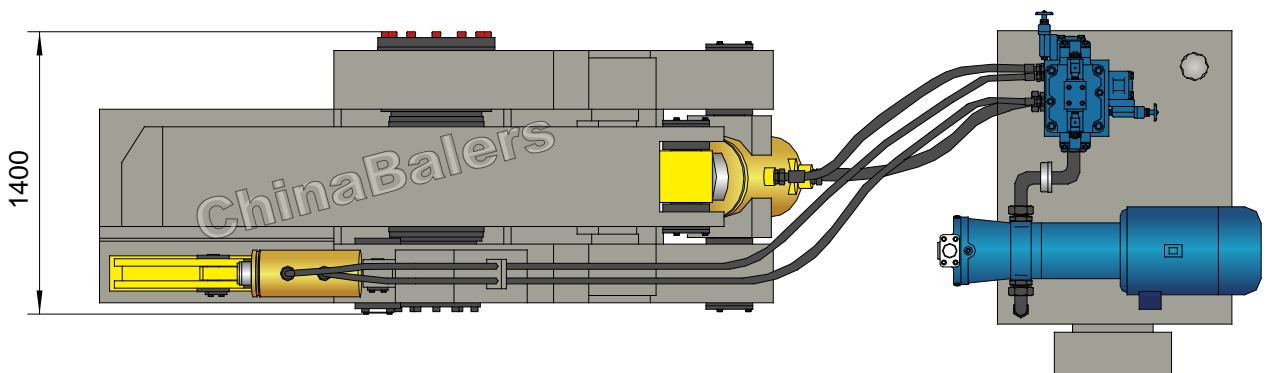

Q43-5000A

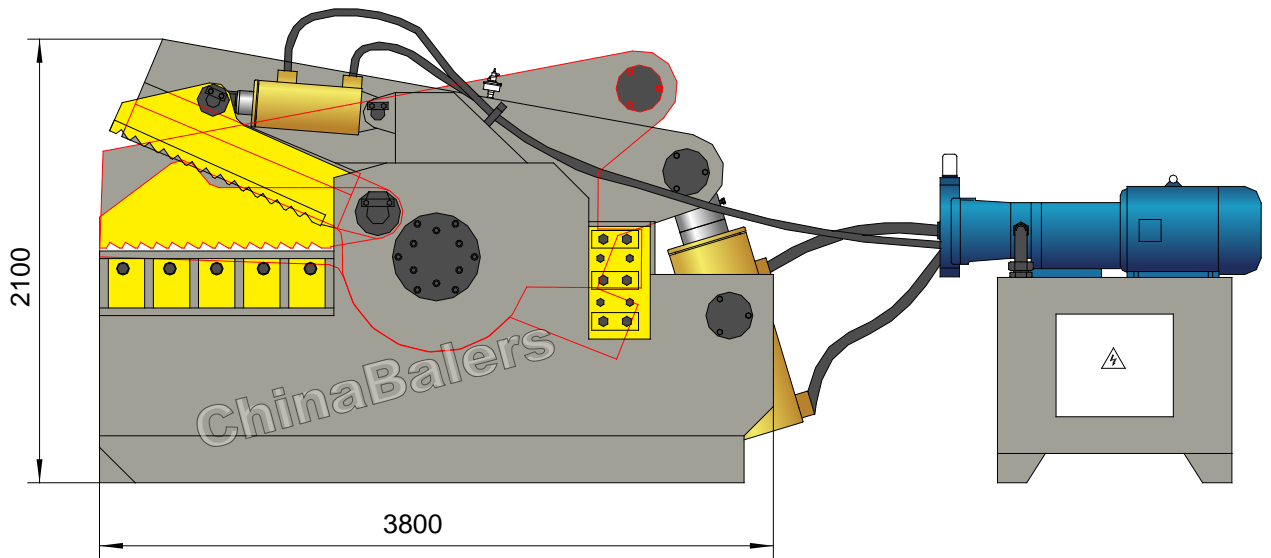
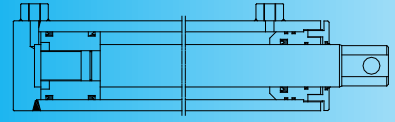
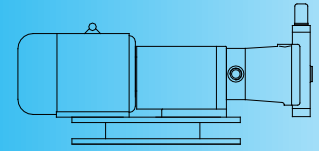

Scrap Metal Cutting Press

Model: Q43-5000A

Power System (Motor, 2 sets)

Type: Y225M-6
 Rated Power: 30 kW (/set)
 Rated Speed: 980 rpm
 Power Spec: 3PH, 50 / 60Hz

Hydraulic System (Pump, 2 sets)

Type: 160YCY14-1B
 Rated Displacement: 160 ml/r (/set)
 Max Operating Pressure: 31.5 MPa

Operation System

Cartridge Valves, PLC Control.

System Parameters

Max. Shearing Force: 500 Ton
 Max. Pressing Force: 42 Ton
 Hydraulic System Pressure: 25 MPa
 Cutting Speed: 4-8 times/min

Max. Cutting Size

Angle Steel: 200×200×16 mm (3 PCS)
 I-beam: 400×146×14.5 mm
 Channel Steel: 400×104×14.5 mm
 Steel Sheet: 20×1400 / 40×600 mm
 Square Billet: 90×90 mm
 Round Steel Bar: φ100 mm

Optional Configuration

NOK (JAPAN) Seal Packings for Cylinders;
 Cooler / Heater; Magnetic Oil Filter;
 Safety Caging;
 Diesel / Diesel Generator for Power.

General Description

Main Machine Size (L×W×H): 3800×1400×2100 mm
 Blade Length: 1600 mm
 Max. Blade Opening: 700 mm
 Shipping Weight: Approx. 15.5 tons
 Loading (Standard Containers): 1×20'GP

Hydraulic Oil Brand

Oil Tank Volume: 2300 ltr

ISO VG	China	U.S.		Britain	France
	GB11118.1	CALTEX CO.	MOBIL	SHELL	ELF CO.
HM 46	46 #	Rando HD46	D.T.E46	Tellus 46	Elfolna 46
HM 68	68 #	Rando HD68	D.T.E68	Tellus 68	Elfolna 68

Above information are indicative not engaging. Rights reserved for change if necessary.