

Y81Q-200

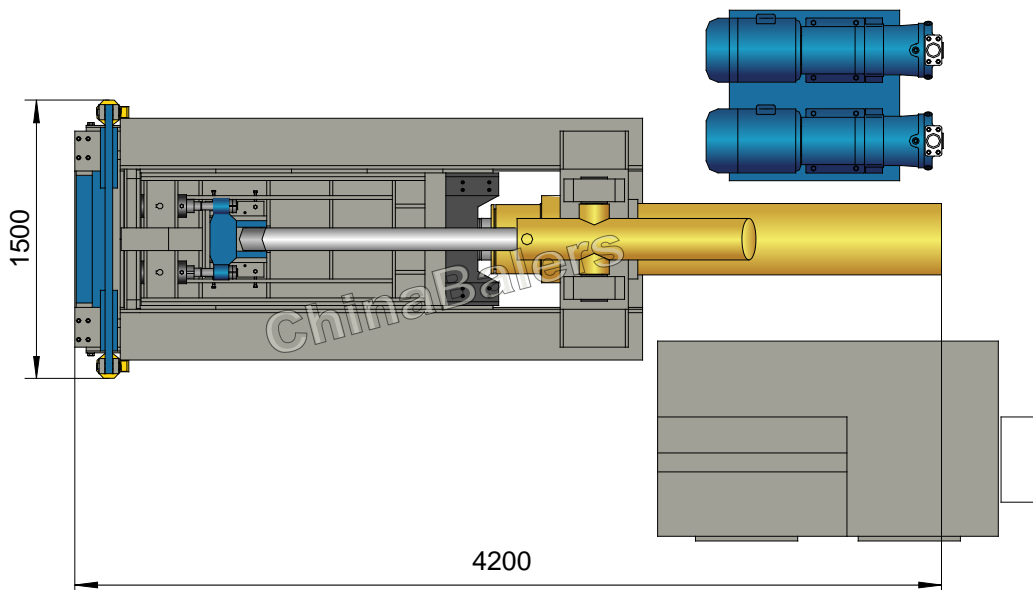

Y81Q-200

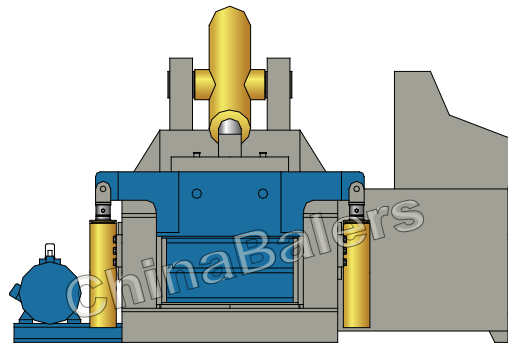
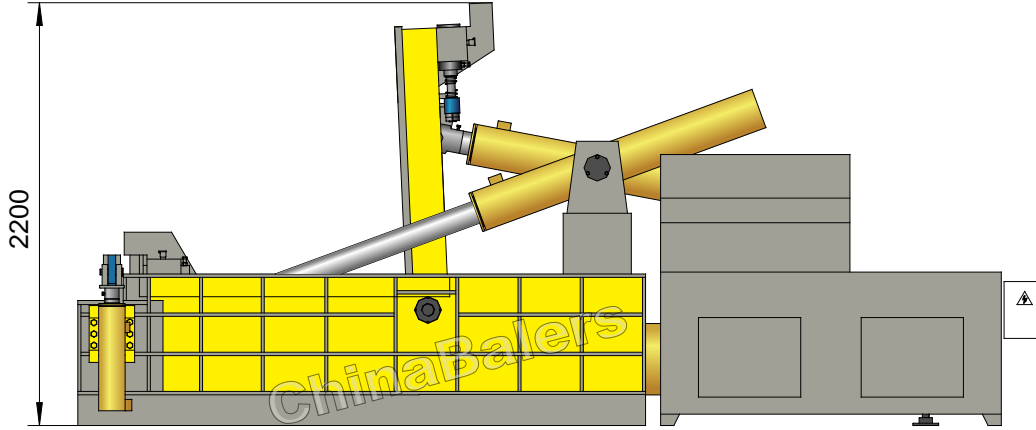
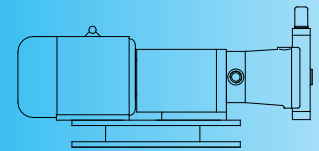

Scrap Baling Plant

Model: Y81Q-200

Power System (Motor, 2 sets)

Type:	Y180M-4
Rated Power:	18.5 kW (/set)
Rated Speed:	1470 rpm
Power Spec:	3PH, 50 / 60Hz

System Parameters

Lid Cyl. Force:	50 Ton
Main Pressure Cyl. Force:	200 Ton
Front Door Cyl. Force:	2×24 Ton
Hydraulic System Pressure:	25 MPa
Idle Cycle Time:	Approx. 70 Sec

Hydraulic System (Pump, 2 sets)

Type:	80YCY14-1B
Rated Displacement:	80 ml/r (/set)
Max Operating Pressure:	31.5 MPa

Standard Configuration

A3 Steel Liners, Surface Heat Treatment.

Operation System (Optional)

- Option 1: Manual Valve Operation
- Option 2: PLC Operation

Optional Configuration

- Cutting Blades & Teeth (2 sides);
- Cooler / Heater;
- Diesel / Diesel Generator for Power.

General Description

Main Machine Size (L×W×H):	4200×1500×2200 mm
Press Box Size (L×W×H):	1400×700×600 mm
Bale Size (W×H):	700×280 mm
Bale Weight (Steel):	70-100 kg
Production Rate (Steel):	1.8-2.5 tons/hr
Shipping Weight:	Approx. 9 tons
Loading (Standard Containers):	

Hydraulic Oil Brand

Oil Tank Volume: 1400 ltr

ISO VG	China	U.S.		Britain	France
	GB11118.1	CALTEX CO.	MOBIL	SHELL	ELF CO.
HM 46	46 #	Rando HD46	D.T.E46	Tellus 46	Elfolna 46
HM 68	68 #	Rando HD68	D.T.E68	Tellus 68	Elfolna 68

Above information are indicative not engaging. Rights reserved for change if necessary.