

HPA100A

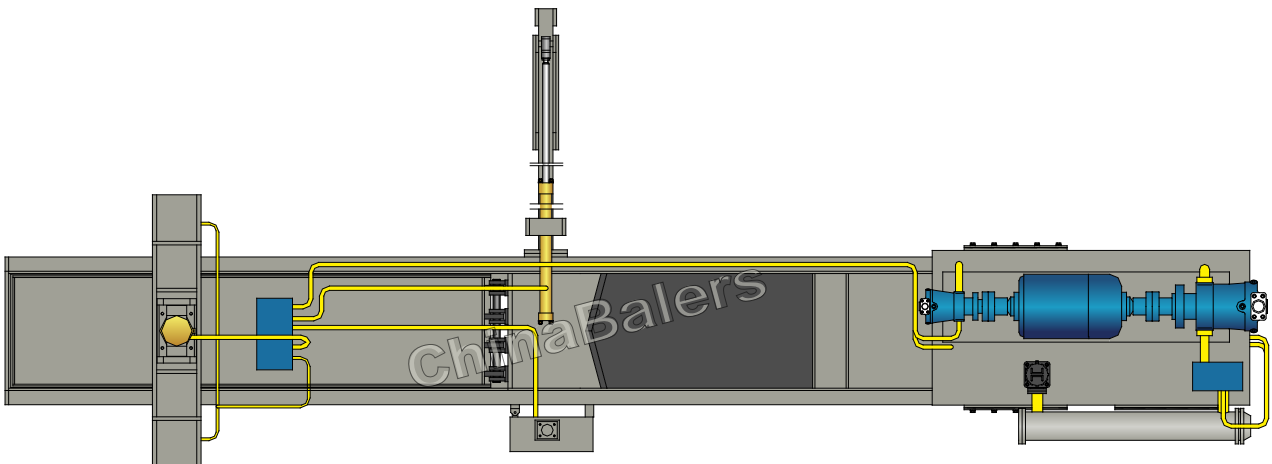

HPA100A

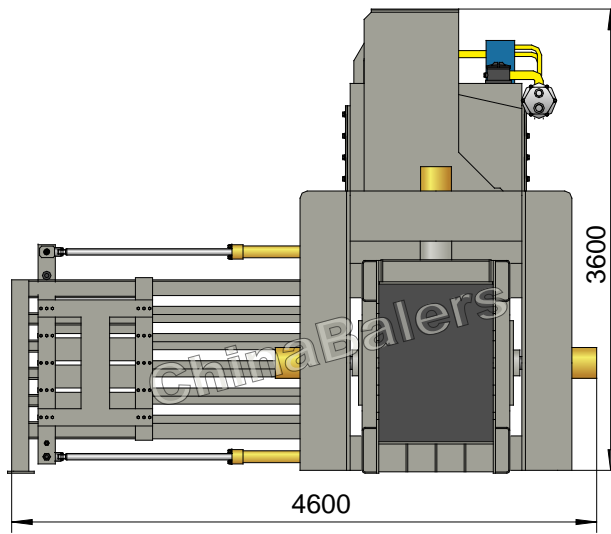
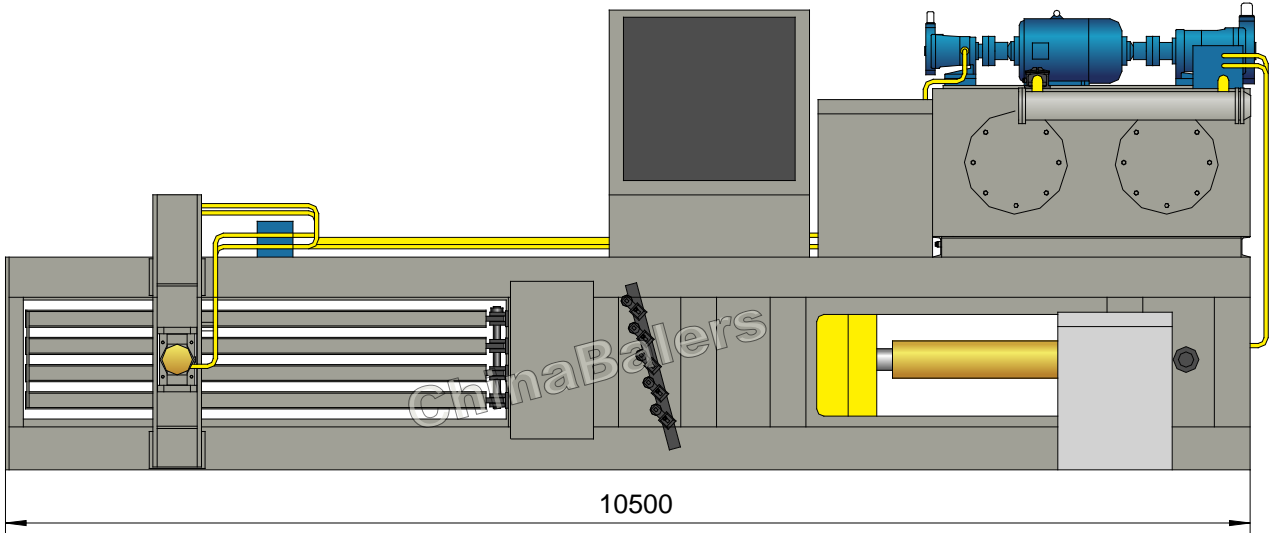
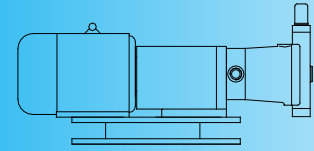

Plastic Press Machine

Model: HPA100A

Power System (Motor, 2 sets)

Motor #1: Y280M-6
 Rated Power: 55 kW
 Rated Speed: 980 rpm

Motor #2: Y160L-4
 Rated Power: 15 kW
 Rated Speed: 1460 rpm

Operation System

Mitsubishi / Siemens PLC & Touch Screen.

Standard Configuration

NOK (JAPAN) Seal Packings for Cylinders;
 V-shaped Cutting Blades; Wire Frame; Oil Cooler;
 Conveyor Width 1400mm, Powered by
 Pump #4 & a Hydraulic Motor.

Optional Configuration

Oil Heater; Magnetic Oil Filter;
 Siemens PLC S7-300 for Long Distance Data Transmission;
 Rexroth Pumps; Siemens Electrical Elements;
 Diesel / Diesel Generator for Power.

General Description

Main Machine Size (L×W×H): 10500×4600×3600 mm
 Feeding Opening (L×W): 1600×1000 mm
 Bale Size (W×H): 1000×1100 mm
 Bale Weight (PET Bottle): 520-700 kg
 Production Rate (PET Bottle): 2.3-3.1 tons/hr
 Strapping: Tempered Iron Wire, ϕ 2.8/3.2mm, 5 Lines, Automatic Strapping.
 Shipping Weight: Approx. 22 + 6.5 tons
 Loading (Standard Containers): 2×40'GP

Hydraulic Oil Brand

Oil Tank Volume: 3100 ltr

ISO VG	China	U.S.		Britain	France
	GB11118.1	CALTEX CO.	MOBIL	SHELL	ELF CO.
HM 46	46 #	Rando HD46	D.T.E46	Tellus 46	Elfolna 46
HM 68	68 #	Rando HD68	D.T.E68	Tellus 68	Elfolna 68

Hydraulic System (Pump, 4 sets)

Pump #1: 250YCY14-1B
 Rated Displacement: 250 ml/r
 Max Operating Pressure: 31.5 MPa

Pump #2: 80YCY14-1B
 Rated Displacement: 80 ml/r
 Max Operating Pressure: 31.5 MPa

Pump #3: 40YCY14-1B
 Rated Displacement: 40 ml/r
 Max Operating Pressure: 31.5 MPa

Pump #4: 25SCY14-1B
 Rated Displacement: 25 ml/r
 Max Operating Pressure: 31.5 MPa

System Parameters

Main Pressure Cyl. Force: 100 Ton
 Necking Cyl. Force: 3×80 Ton
 Wire Pushing Cyl. Force: 8 Ton
 Wire Cutting Cyl. Force: 8 Ton
 Hydraulic System Pressure: 25 MPa