

YE81T-200C

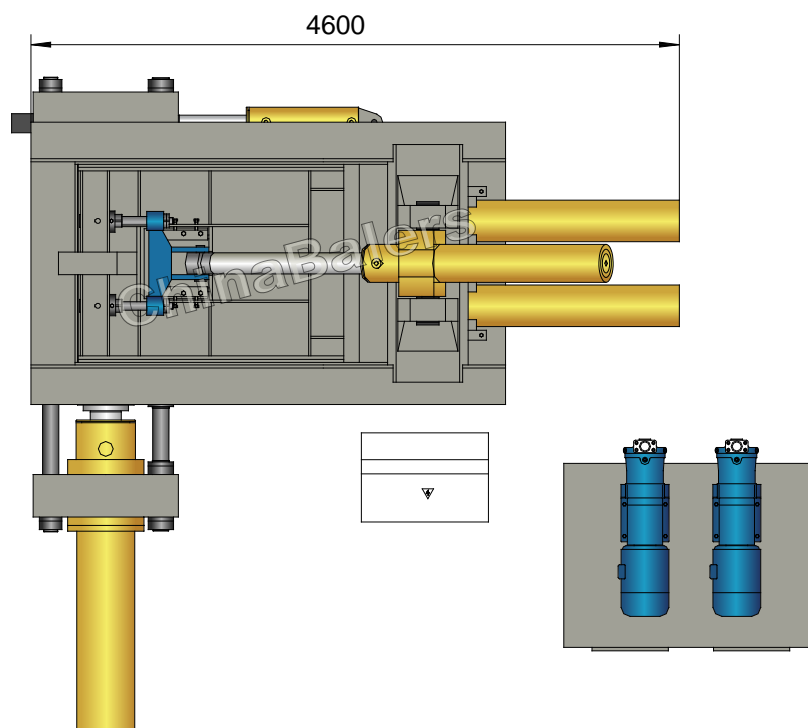

YE81T-200C

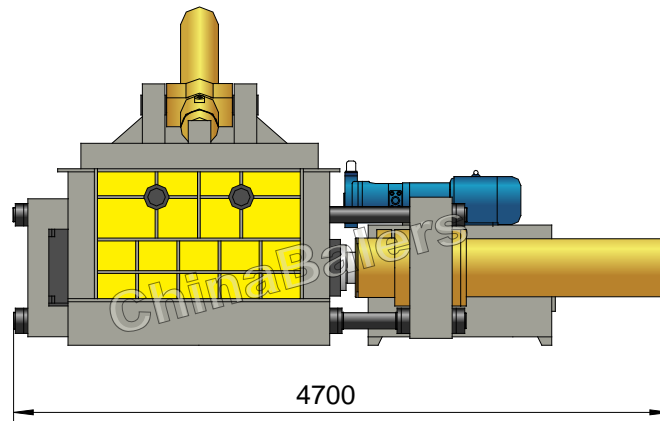
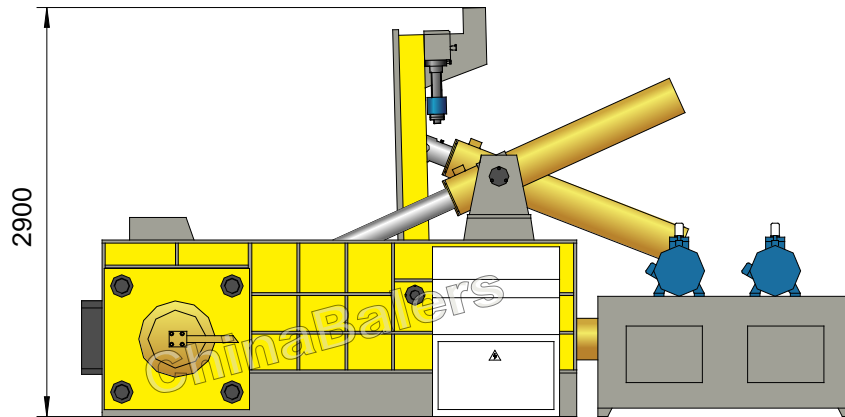
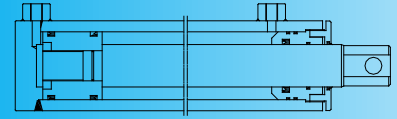
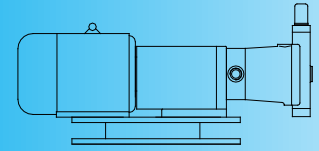

Non Ferrous Waste Baler

Model: YE81T-200C

Power System (Motor, 2 sets)

Type:	Y200L2-6
Rated Power:	22 kW (/set)
Rated Speed:	970 rpm
Power Spec:	3PH, 50 / 60Hz

Hydraulic System (Pump, 2 sets)

Type:	160YCY14-1B
Rated Displacement:	160 ml/r (/set)
Max Operating Pressure:	31.5 MPa

Standard Configuration

#45 Steel Liners 20mm, Wholly Heat Treated;
NOK (JAPAN) Seal Packings for Cylinders;
Cooler / Heater; Magnetic Oil Filter.

System Parameters

Lid Cyl. Force:	80 Ton
Side Pressure Cyl. Force:	2×100 Ton
Main Pressure Cyl. Force:	200 Ton
Small Door Cyl. Force:	50 Ton
Hydraulic System Pressure:	25 MPa
Idle Cycle Time:	Approx. 110 Sec

Operation System (Optional)

Option 1: Manual Valve Operation
Option 2: PLC Operation

Optional Configuration

Cutting Blades & Teeth (2 sides); Loading Hopper;
Mn65 Steel Liners for High Pressure Chamber;
Diesel / Diesel Generator for Power.

General Description

Main Machine Size (L×W×H):	4600×4700×2900 mm
Press Box Size (L×W×H):	1800×1400×1000 mm
Bale Size (W×H):	400×400 / 450×450 mm
Bale Weight:	Alu 60-120, SS 180-350, Copper 200-380 kg
Production Rate:	Alu 1.2-2.1, SS 3.5-6.0, Copper 3.8-6.5 tons/hr
Shipping Weight:	Approx. 25 tons
Loading (Standard Containers):	2×20'GP

Hydraulic Oil Brand

Oil Tank Volume: 2300 ltr

ISO VG	China	U.S.		Britain	France
	GB11118.1	CALTEX CO.	MOBIL	SHELL	ELF CO.
HM 46	46 #	Rando HD46	D.T.E46	Tellus 46	Elfolna 46
HM 68	68 #	Rando HD68	D.T.E68	Tellus 68	Elfolna 68

Above information are indicative not engaging. Rights reserved for change if necessary.