

# YE81F-250B

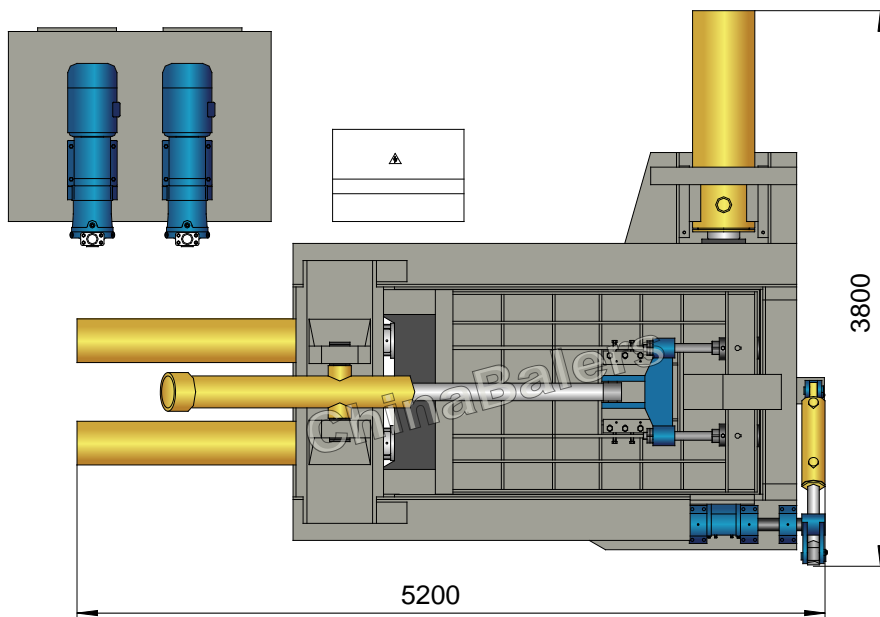

# YE81F-250B

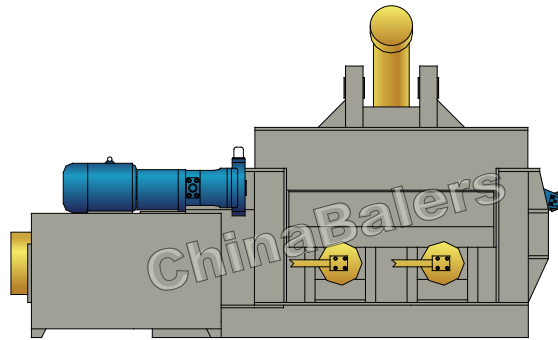
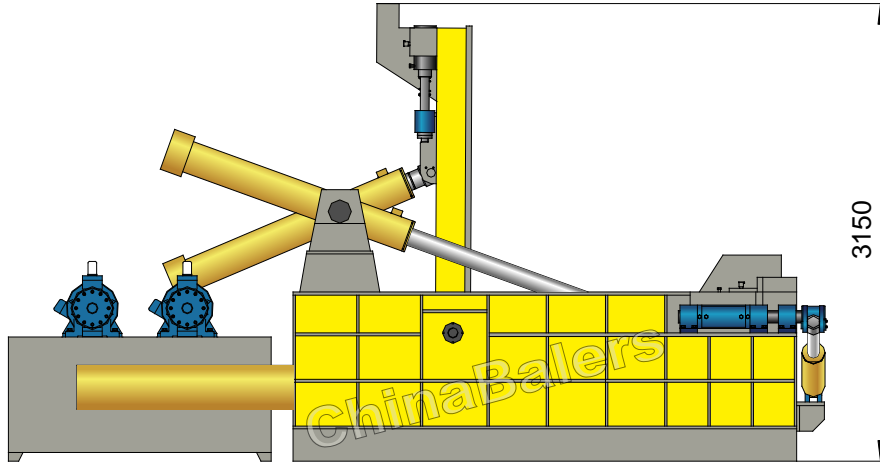

## Metal Recycling Baler

Model: YE81F-250B

### Power System (Motor, 2 sets)

Type:	Y200L2-6
Rated Power:	22 kW (/set)
Rated Speed:	970 rpm
Power Spec:	3PH, 50 / 60Hz

### Hydraulic System (Pump, 2 sets)

Type:	160YCY14-1B
Rated Displacement:	160 ml/r (/set)
Max Operating Pressure:	31.5 MPa

### Standard Configuration

#45 Steel Liners 20mm, Wholly Heat Treated;  
NOK (JAPAN) Seal Packings for Cylinders;  
Cooler / Heater; Magnetic Oil Filter.

### System Parameters

Lid Cyl. Force:	80 Ton
Side Pressure Cyl. Force:	2×120 Ton
Main Pressure Cyl. Force:	250 Ton
Bale Discharge Cyl. Force:	8 Ton
Hydraulic System Pressure:	25 MPa
Idle Cycle Time:	Approx. 120 Sec

### Operation System

Manual Valve Operation

### Optional Configuration

Cutting Blades & Teeth (2 sides);  
Mn65 Steel Liners for High Pressure Chamber;  
Diesel / Diesel Generator for Power.

### General Description

Main Machine Size (L×W×H):	5200×3800×3150 mm
Press Box Size (L×W×H):	2000×1400×900 mm
Bale Size (W×H):	450×450 / 500×500 / Octagon 500 mm
Bale Weight (Steel):	250-450 kg
Production Rate (Steel):	4.5-7.0 tons/hr
Shipping Weight:	Approx. 19.5 tons
Loading (Standard Containers):	1×20'OT

### Hydraulic Oil Brand

Oil Tank Volume: 2300 ltr

ISO VG	China	U.S.		Britain	France
	GB11118.1	CALTEX CO.	MOBIL	SHELL	ELF CO.
HM 46	46 #	Rando HD46	D.T.E46	Tellus 46	Elfolna 46
HM 68	68 #	Rando HD68	D.T.E68	Tellus 68	Elfolna 68

Above information are indicative not engaging. Rights reserved for change if necessary.