

YE83-500

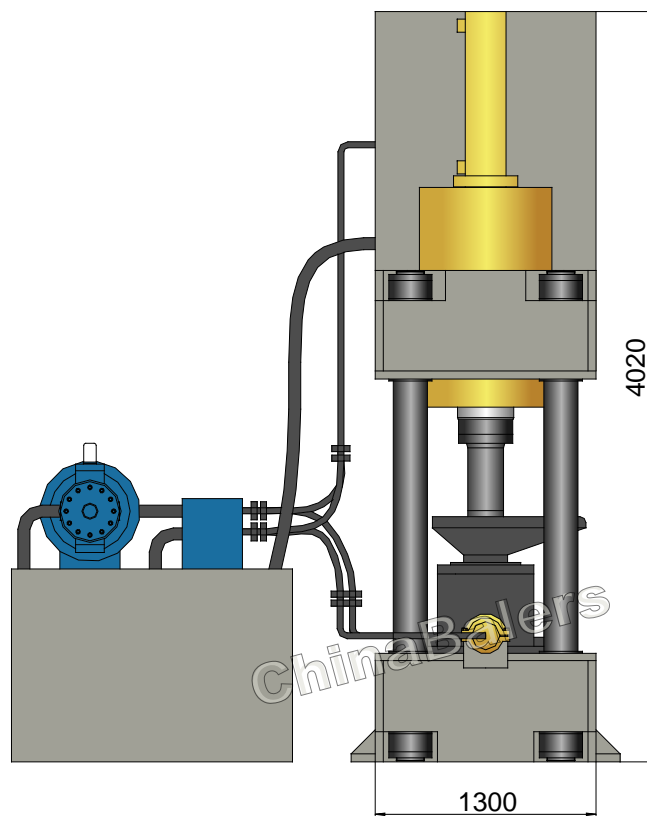

YE83-500

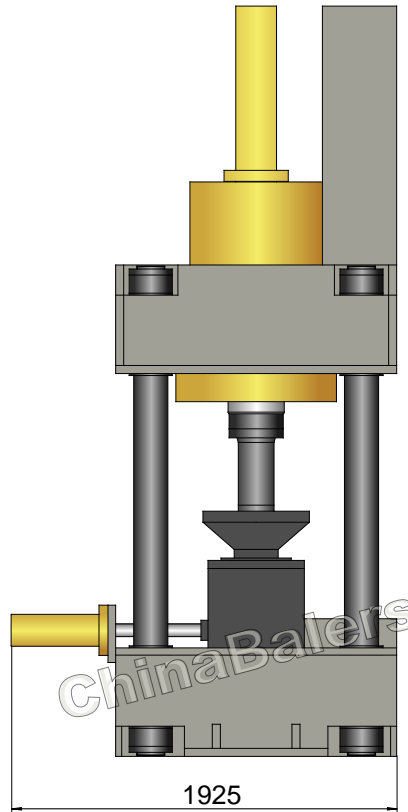

Metal Briquetting Press

Model: YE83-500

Power System (Motor)

Type:	Y280S-6
Rated Power:	45 kW
Rated Speed:	980 rpm
Power Spec:	3PH, 50 / 60Hz

System Parameters

Main Cyl. Force:	490 Ton
Auxiliary Cyl. Force:	60 Ton
Discharging Cyl. Force:	30 Ton
Hydraulic System Pressure:	25 MPa
Idle Cycle Time:	15-18 Sec

Hydraulic System (Pump)

Type	250YCY14-1B
Rated Displacement:	250 ml/r
Max Operating Pressure:	31.5 MPa

Operation System

PLC Operation

Standard Configuration

NOK (JAPAN) Seal Packings for Cylinders;
Cooler / Heater; Magnetic Oil Filter.

Optional Configuration

Feeding Conveyor & Vibrating Motor;
Diesel / Diesel Generator for Power.

General Description

Main Machine Size (L×W×H):	1925×1300×4020 mm
Press Mould Size (Dia×H):	Φ150×300 / Φ180×300 mm
Pressure on Briquet:	283 / 196 MPa
Briquet Size (Dia×H):	Φ150×(70-100) / Φ180×(70-100) mm
Briquet Weight (Cast Iron):	6.9-9.9 / 8.9-12.8 kg
Production Rate (Cast Iron):	1300-1800 kg/hr
Shipping Weight:	Approx. 15 tons
Loading (Standard Containers):	1×40'GP

Hydraulic Oil Brand

Oil Tank Volume: 2500 ltr

ISO VG	China	U.S.		Britain	France
	GB11118.1	CALTEX CO.	MOBIL	SHELL	ELF CO.
HM 46	46 #	Rando HD46	D.T.E46	Tellus 46	Elfolna 46
HM 68	68 #	Rando HD68	D.T.E68	Tellus 68	Elfolna 68

Above information are indicative not engaging. Rights reserved for change if necessary.