

Y83-315

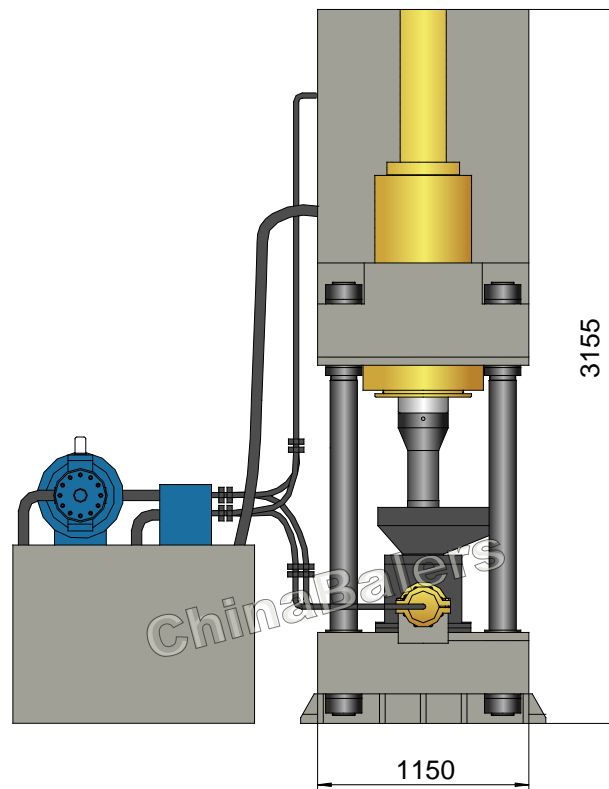

Y83-315

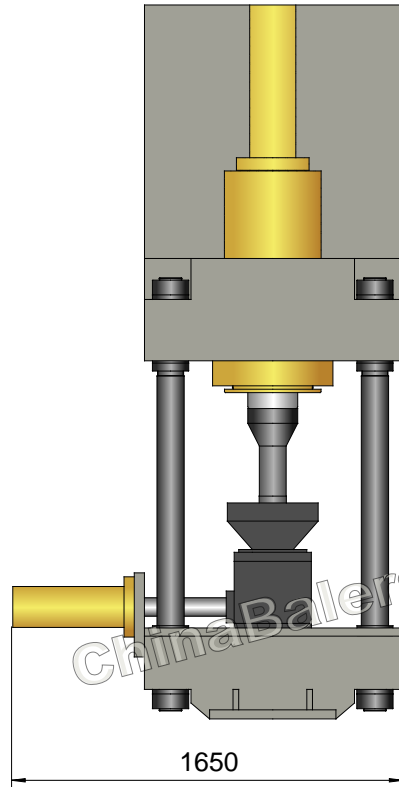

Metal Briquette Machine

Model: Y83-315

Power System (Motor)

Type:	Y200L2-6
Rated Power:	22 kW
Rated Speed:	970 rpm
Power Spec:	3PH, 50 / 60Hz

System Parameters

Main Cyl. Force:	285 Ton
Auxiliary Cyl. Force:	55 Ton
Discharging Cyl. Force:	30 Ton
Hydraulic System Pressure:	25 MPa
Idle Cycle Time:	10-12 Sec

Hydraulic System (Pump)

Pump #1:	160YCY14-1B
Rated Displacement:	160 ml/r
Max Operating Pressure:	31.5 MPa

Operation System

PLC Operation

Pump #2:	63YCY14-1B
Rated Displacement:	63 ml/r
Max Operating Pressure:	31.5 MPa

Optional Configuration

Cooler / Heater;
Feeding Conveyor & Vibrating Motor;
Diesel / Diesel Generator for Power.

General Description

Main Machine Size (L×W×H):	1650×1150×3155 mm
Press Mould Size (Dia×H):	Φ120×180 / Φ140×180 mm
Pressure on Briquet:	278 / 204 MPa
Briquet Size (Dia×H):	Φ120×(50-70) / Φ140×(50-70) mm
Briquet Weight (Cast Iron):	3.1-4.5 / 3.6-5.1 kg
Production Rate (Cast Iron):	900-1100 kg/hr
Shipping Weight:	Approx. 8 tons
Loading (Standard Containers):	

Hydraulic Oil Brand

Oil Tank Volume: 2500 ltr

ISO VG	China	U.S.		Britain	France
	GB11118.1	CALTEX CO.	MOBIL	SHELL	ELF CO.
HM 46	46 #	Rando HD46	D.T.E46	Tellus 46	Elfolna 46
HM 68	68 #	Rando HD68	D.T.E68	Tellus 68	Elfolna 68

Above information are indicative not engaging. Rights reserved for change if necessary.