

HBS-500

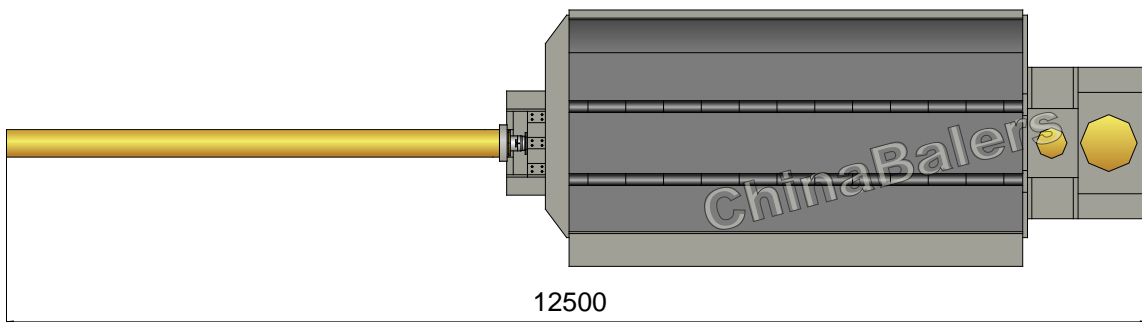

HBS-500

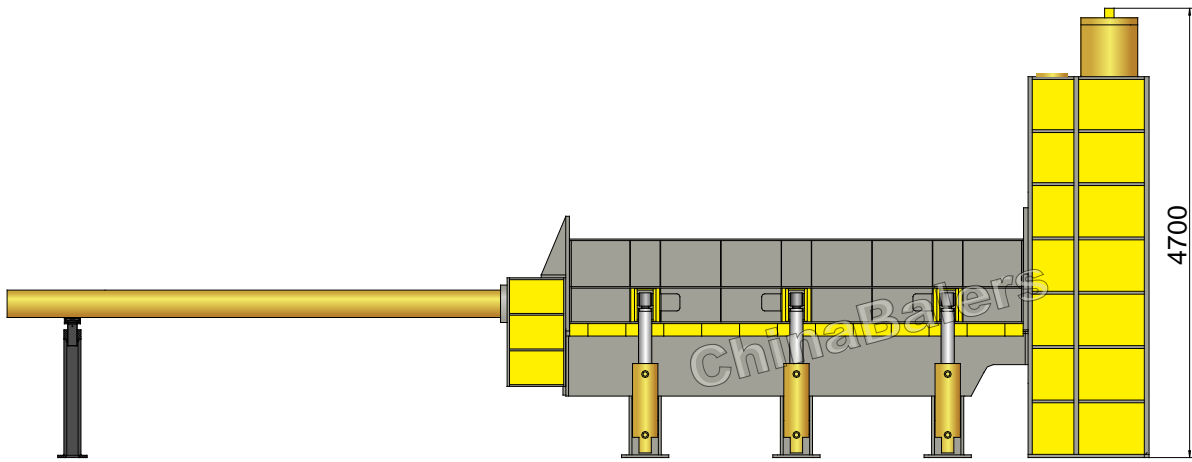
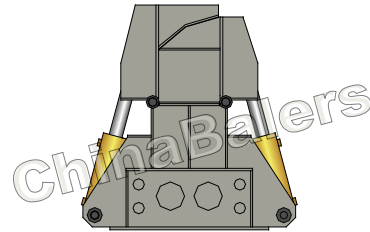
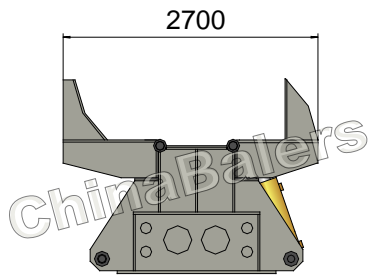

Hydraulic Shear Baler

Model: HBS-500

Power System (Motor, 2+1 sets)

Type: Y280M-4
 Rated Power: 90 kW (/set)
 Rated Speed: 1480 rpm

Hydraulic System (Pump, 4+2 sets)

Type: LY-A7V160
 Rated Displacement: 160 ml/r (/set)
 Max Operating Pressure: 35 MPa

Operation System

Siemens PLC & Remote Controller.

Max. Cutting Size

Steel Sheet: 60×600 mm
 Square Billet: 100×100 mm
 Round Steel Bar: φ110 mm

General Description

Main Machine Size (L×W×H): 12500×2750×4700 mm
 Feed Opening (L×W): 4800×2240 mm
 Bale Size (W×H): 650×550 mm
 Blade Width & Angle: 750 mm; 10 Degree
 Production Rate (Steel): 5.5-15 tons/hr
 Total Installed Power: 3PH, 50/60 Hz, 300 kW
 Space Required: <21000×10500 mm
 Shipping Weight: Approx. 69 tons
 Loading (Standard Containers): 2×40'GP + 1×40'OT + 1×20'OT

System Parameters

Shear Cyl. Force: 500 Ton
 Stamper Cyl. Force: 155 Ton
 Wing Cyl. Force: 3×63 Ton
 Lid Cyl. Force: 3×80 Ton
 Pushing Cyl. Force: 100 Ton
 Hydraulic System Pressure: 31.5/25 MPa
 Cutting Speed: 3-4 times/min

Standard Configuration

NOK (JAPAN) Seal Packings for Cylinders;
 Oil Cooling & Filtering System;
 Long Distance Data Transmission.

Optional Configuration

Tank Heater;
 Diesel / Diesel Generator for Power.

Hydraulic Oil Brand

Oil Tank Volume: 8000 ltr

ISO VG	China	U.S.		Britain	France
	GB11118.1	CALTEX CO.	MOBIL	SHELL	ELF CO.
HM 46	46 #	Rando HD46	D.T.E46	Tellus 46	Elfolna 46
HM 68	68 #	Rando HD68	D.T.E68	Tellus 68	Elfolna 68

Above information are indicative not engaging. Rights reserved for change if necessary.