

# QE43-400

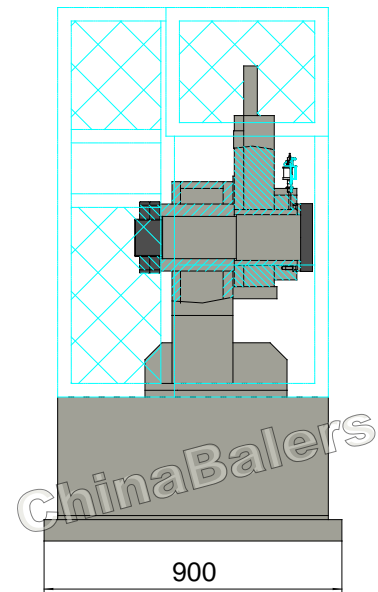

# QE43-400

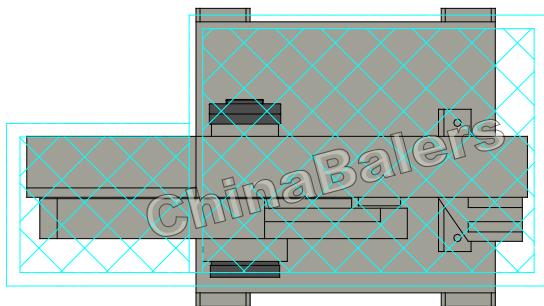
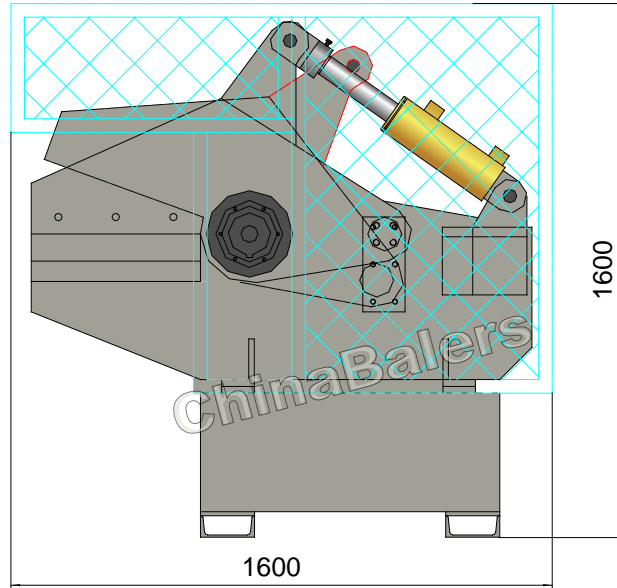

## Hydraulic Cutter

Model: QE43-400

### Power System (Motor)

Type: 7.5P-V524-V18  
Rated Power: 5.5 kW  
Rated Speed: 1740 rpm  
Power Spec: 3PH, 50 / 60Hz

### Hydraulic System (Pump)

Type: V18A4R  
Rated Displacement: 17.8 ml/r  
Max Operating Pressure: 25 MPa

### Operation System

Pedal Valve Operation

### System Parameters

Max. Shearing Force: 40 Ton  
Hydraulic System Pressure: 13 MPa  
Cutting Speed: 8-12 times/min

### Max. Cutting Size

Angle Steel: 40×40×4 mm (2 PCS)  
Steel Sheet: 8×100 mm  
Square Billet: 25×25 mm  
Round Steel Bar: φ28 mm

### Standard Configuration

NOK (JAPAN) Seal Packings for Cylinders;  
Safety Caging.

### General Description

Main Machine Size (L×W×H): 1600×900×1600 mm  
Blade Length: 500 mm  
Max. Blade Opening: 200 mm  
Shipping Weight: Approx. 1.5 tons  
Loading (Standard Containers): 1/7×20'GP

### Hydraulic Oil Brand

Oil Tank Volume: 200 ltr

ISO VG	China	U.S.		Britain	France
		GB11118.1	CALTEX CO.	MOBIL	SHELL
HM 46	46 #	Rando HD46	D.T.E46	Tellus 46	Elfolna 46
HM 68	68 #	Rando HD68	D.T.E68	Tellus 68	Elfolna 68

Above information are indicative not engaging. Rights reserved for change if necessary.