

Q43-1200A

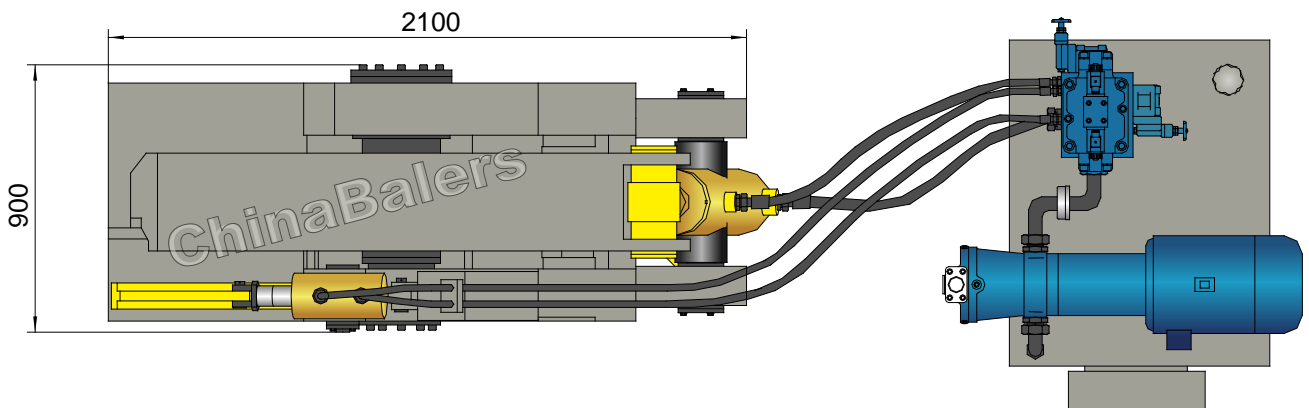

Q43-1200A

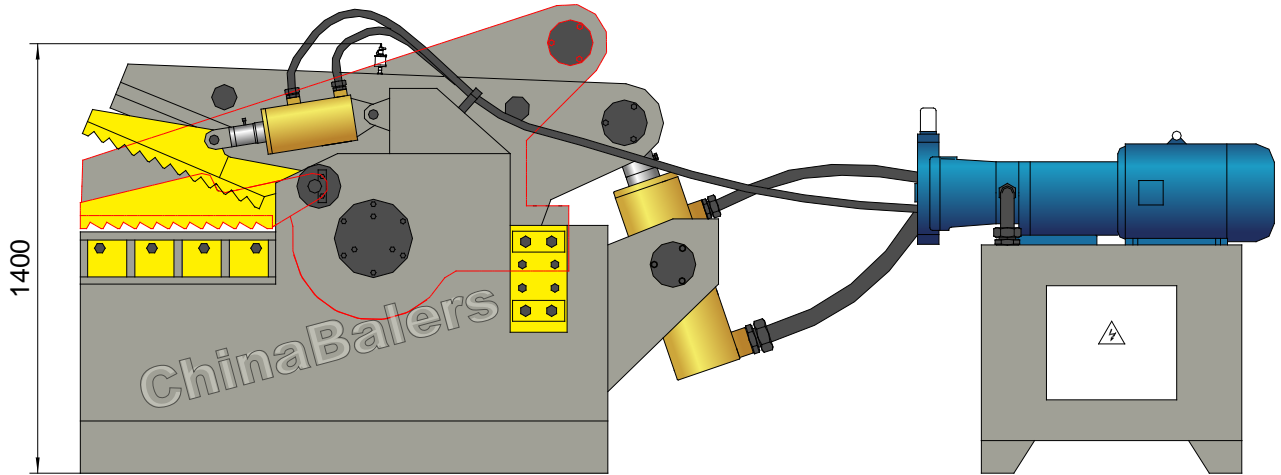
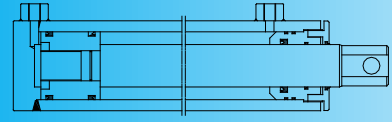

Hydraulic Alligator Shear

Model: Q43-1200A

Power System (Motor)

Type: Y160L-4
 Rated Power: 15 kW
 Rated Speed: 1460 rpm
 Power Spec: 3PH, 50 / 60Hz

Hydraulic System (Pump)

Type: 63YCY14-1B
 Rated Displacement: 63 ml/r
 Max Operating Pressure: 31.5 MPa

Operation System

Hydro-electrical Valves, Push Button Control.

System Parameters

Max. Shearing Force: 120 Ton
 Max. Pressing Force: 20 Ton
 Hydraulic System Pressure: 21 MPa
 Cutting Speed: 8-12 times/min

Max. Cutting Size

Angle Steel: 100×100×10 mm (3 PCS)
 Channel Steel: 180×68×8 mm
 Steel Sheet: 25×140 mm
 Square Billet: 40×40 mm
 Round Steel Bar: φ45 mm

Optional Configuration

NOK (JAPAN) Seal Packings for Cylinders;
 Cooler / Heater; Magnetic Oil Filter;
 Safety Caging;
 Diesel / Diesel Generator for Power.

General Description

Main Machine Size (L×W×H): 2100×900×1400 mm
 Blade Length: 600 mm
 Max. Blade Opening: 270 mm
 Shipping Weight: Approx. 3.3 tons
 Loading (Standard Containers): 1/3×20'GP

Hydraulic Oil Brand

Oil Tank Volume: 450 ltr

| ISO VG | China | U.S. | | Britain | France |
|--------|-----------|------------|---------|-----------|------------|
| | GB11118.1 | CALTEX CO. | MOBIL | SHELL | ELF CO. |
| HM 46 | 46 # | Rando HD46 | D.T.E46 | Tellus 46 | Elfolna 46 |
| HM 68 | 68 # | Rando HD68 | D.T.E68 | Tellus 68 | Elfolna 68 |

Above information are indicative not engaging. Rights reserved for change if necessary.