

# HPM250

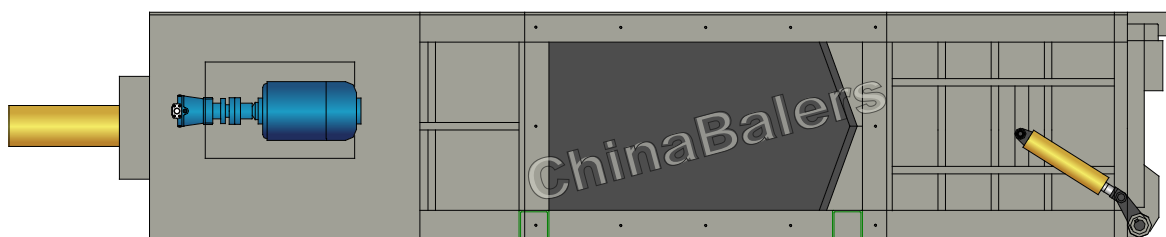

# HPM250

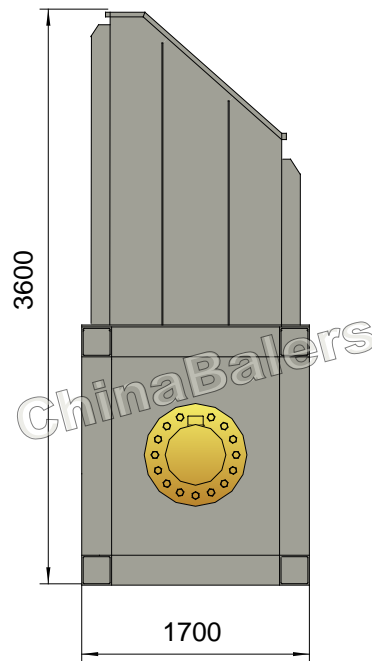
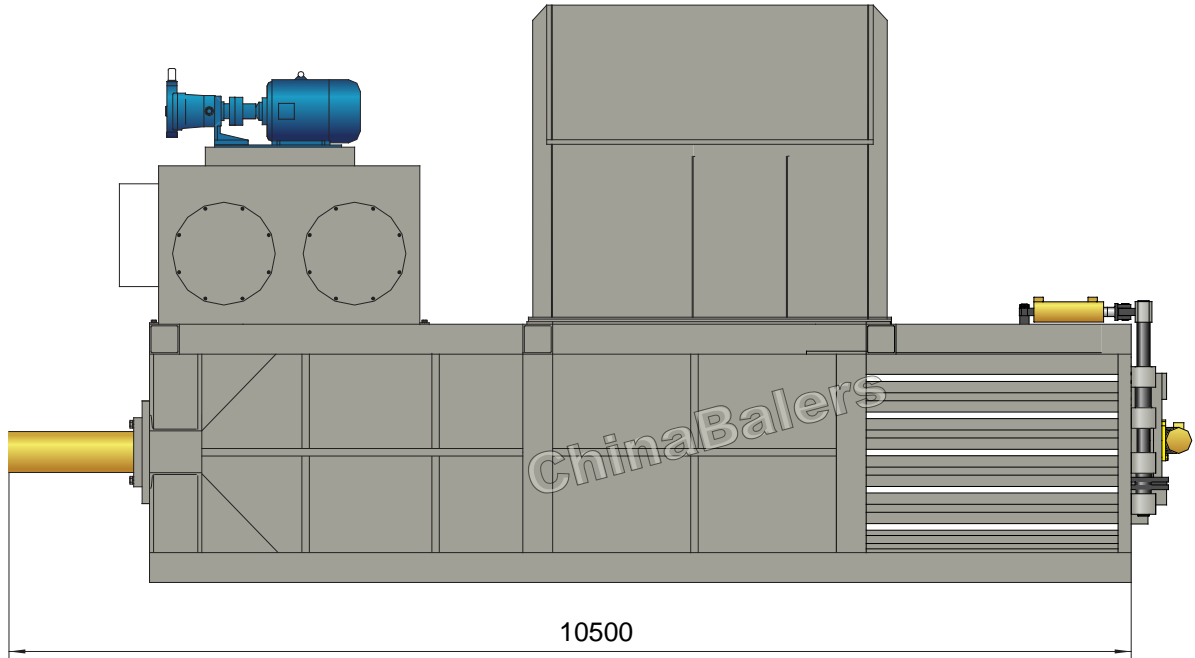
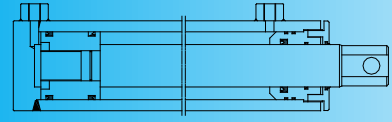
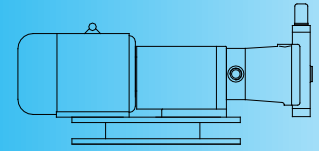

## Horizontal Cardboard Baler

Model: HPM250

### Power System (Main Motor, 2 sets)

Type: Y280S-6  
 Rated Power: 45 kW (/set)  
 Rated Speed: 980 rpm  
 Power Spec: 3PH, 50 / 60Hz

### System Parameters

Main Pressure Cyl. Force: 250 Ton  
 Locking Cyl. Force: 30 Ton  
 Open-door Cyl. Force: 23.5 Ton  
 Hydraulic System Pressure: 25 MPa

### Hydraulic System (Pump, 3 sets)

Pump #1, #2: 250YCY14-1B  
 Rated Displacement: 250 ml/r (/set)  
 Max Operating Pressure: 31.5 MPa

Pump #3: 25YCY14-1B  
 Rated Displacement: 25 ml/r  
 Max Operating Pressure: 31.5 MPa

### Standard Configuration

V-shaped Cutting Blades; Oil Cooler;  
 Conveyor Width 1600mm, Powered by 7.5kW Motor;  
 Discharging Roll Powered by 0.75kW Motor.

### Optional Configuration

NOK (JAPAN) Seal Packings for Cylinders;  
 Oil Heater; Magnetic Oil Filter;  
 Diesel / Diesel Generator for Power.

### Operation System

PLC Operation

### General Description

Main Machine Size (L×W×H): 10500×1700×3600 mm  
 Feeding Opening (L×W): 2200×1120 mm  
 Bale Size (W×H): 1120×1300 mm  
 Bale Weight (Cardboard): 1050-1500 kg  
 Production Rate (Cardboard): 6.3-9.5 tons/hr  
 Strapping: Tempered Iron Wire,  $\phi$ 3.6/4.0mm, 7 Lines, Manual Strapping.  
 Shipping Weight: Approx. 21 + 7 tons  
 Loading (Standard Containers): 2×40'GP

### Hydraulic Oil Brand

Oil Tank Volume: 3200 ltr

ISO VG	China	U.S.		Britain	France
	GB11118.1	CALTEX CO.	MOBIL	SHELL	ELF CO.
HM 46	46 #	Rando HD46	D.T.E46	Tellus 46	Elfolna 46
HM 68	68 #	Rando HD68	D.T.E68	Tellus 68	Elfolna 68

Above information are indicative not engaging. Rights reserved for change if necessary.