

# Y83-400

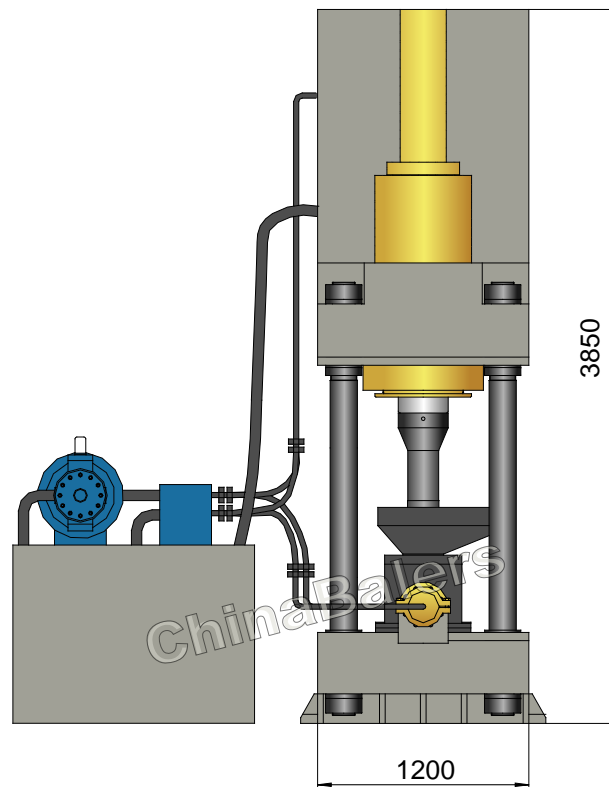

# Y83-400

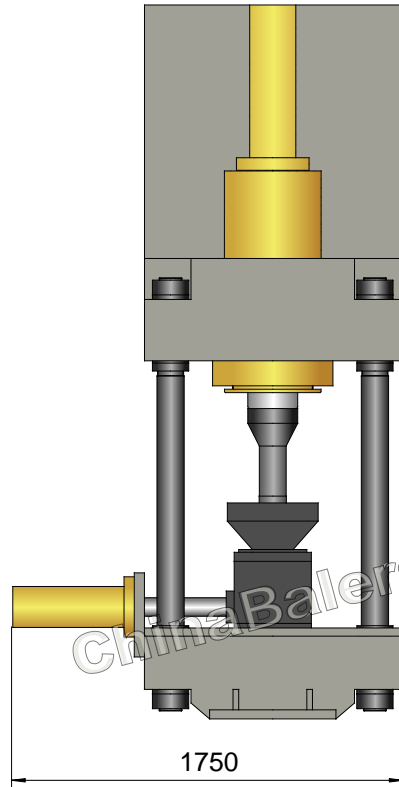

## Chip Briquetting Machine

Model: Y83-400

### Power System (Motor)

Type:	Y225M-6 / Y250M-6
Rated Power:	30 / 37 kW
Rated Speed:	980 rpm
Power Spec:	3PH, 50 / 60Hz

### System Parameters

Main Cyl. Force:	345 Ton
Auxiliary Cyl. Force:	55 Ton
Discharging Cyl. Force:	30 Ton
Hydraulic System Pressure:	25 MPa
Idle Cycle Time:	15-18 Sec

### Hydraulic System (Pump)

Pump #1:	160YCY14-1B
Rated Displacement:	160 ml/r
Max Operating Pressure:	31.5 MPa

### Operation System

PLC Operation

Pump #2:	80YCY14-1B
Rated Displacement:	80 ml/r
Max Operating Pressure:	31.5 MPa

### Optional Configuration

Cooler / Heater;  
Feeding Conveyor & Vibrating Motor;  
Diesel / Diesel Generator for Power.

### General Description

Main Machine Size (L×W×H):	1750×1200×3850 mm
Press Mould Size (Dia×H):	Φ125×300 / Φ140×300 mm
Pressure on Briquet:	326 / 260 MPa
Briquet Size (Dia×H):	Φ125×(70-100) / Φ140×(70-100) mm
Briquet Weight (Cast Iron):	5-7.2 / 5.9-8.5 kg
Production Rate (Cast Iron):	1200-1300 kg/hr
Shipping Weight:	Approx. 11 tons
Loading (Standard Containers):	

### Hydraulic Oil Brand

Oil Tank Volume: 2500 ltr

ISO VG	China	U.S.		Britain	France
	GB11118.1	CALTEX CO.	MOBIL	SHELL	ELF CO.
HM 46	46 #	Rando HD46	D.T.E46	Tellus 46	Elfolna 46
HM 68	68 #	Rando HD68	D.T.E68	Tellus 68	Elfolna 68

Above information are indicative not engaging. Rights reserved for change if necessary.