

Y82T-63F

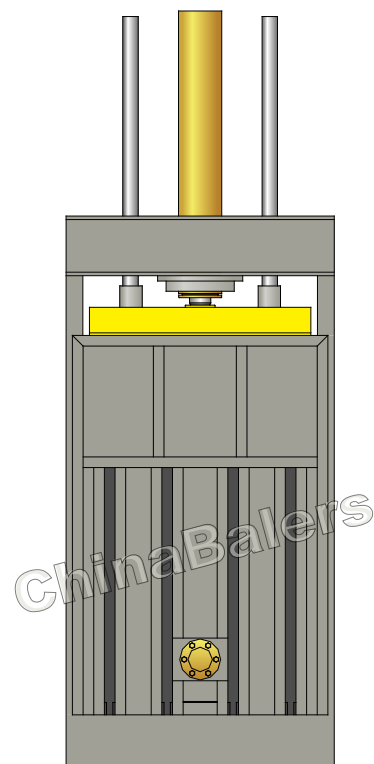

Y82T-63F

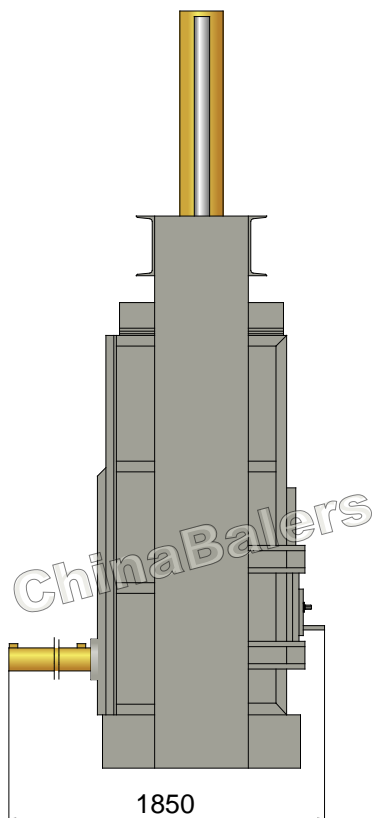
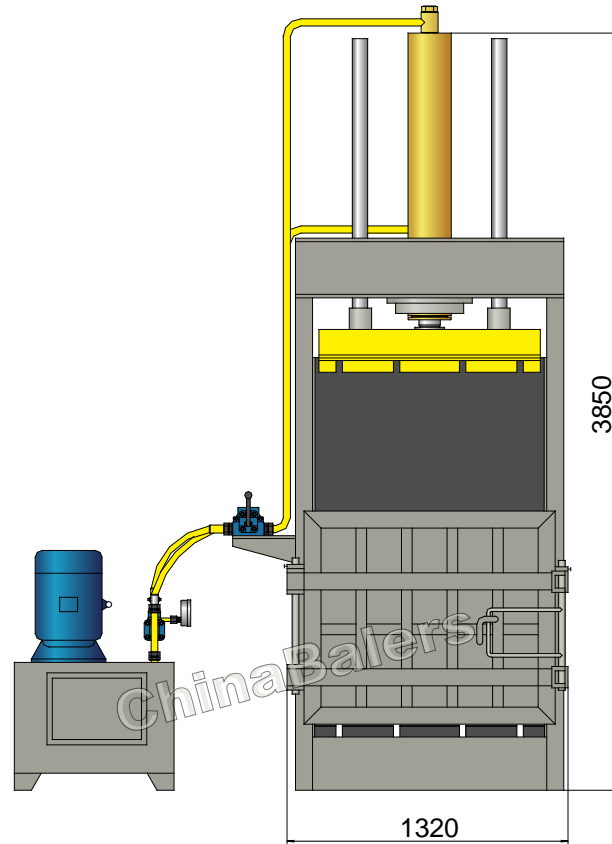

Cardboard Box Baler

Model: Y82T-63F

Power System (Motor)

Type:	Y180L-6
Rated Power:	15 kW
Rated Speed:	970 rpm
Power Spec:	3PH, 50 / 60Hz

System Parameters

Main Pressure Cyl. Force:	63 Ton
Ejection Cyl. Force:	10 Ton
Hydraulic System Pressure:	20 MPa

Hydraulic System (Pump)

Type:	63YCY14-1B
Rated Displacement:	63 ml/r
Max Operating Pressure:	31.5 MPa

Standard Configuration

NOK (JAPAN) Seal Packings for Cylinders.

Operation System

Manual Valve Operation

General Description

Main Machine Size (L×W×H):	1550×1850×3850 mm
Press Box Size (L×W×H):	1100×800×1500 mm
Space Between Ram & Bottom:	Max. 1500 mm; Min. 300 mm
Bale Size (L×W):	1100×800 mm
Bale Weight (Cardboard):	200-300 kg
Production Rate (Cardboard):	600-1000 kg/hr
Strapping:	Tempered Iron Wire, ϕ 2.8/3.2mm, 4 Lines, Manual Strapping.
Bale Discharging:	By Ejection Cylinder
Shipping Weight:	Approx. 3.5 tons
Loading (Standard Containers):	1/2×20'GP

Hydraulic Oil Brand

Oil Tank Volume: 320 ltr

ISO VG	China	U.S.		Britain	France
	GB11118.1	CALTEX CO.	MOBIL	SHELL	ELF CO.
HM 46	46 #	Rando HD46	D.T.E46	Tellus 46	Elfolna 46
HM 68	68 #	Rando HD68	D.T.E68	Tellus 68	Elfolna 68

Above information are indicative not engaging. Rights reserved for change if necessary.