

# HPA80A

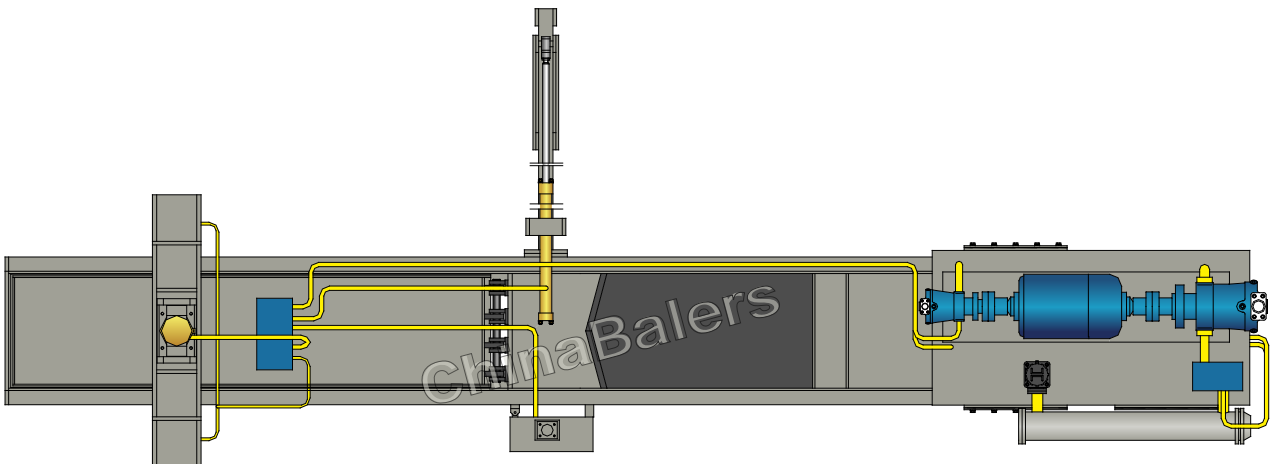

# HPA80A

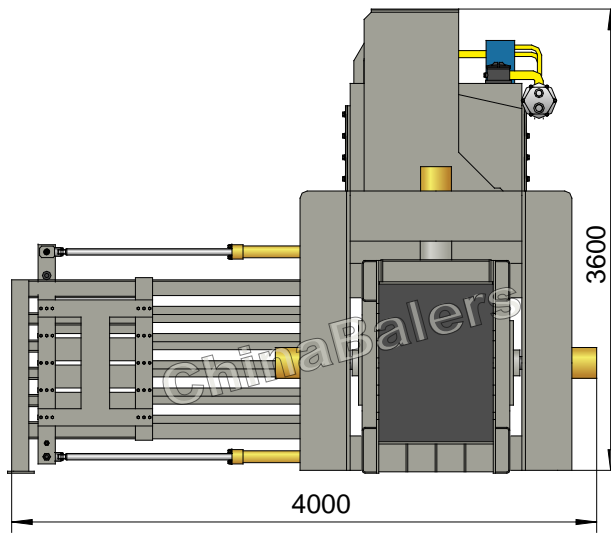
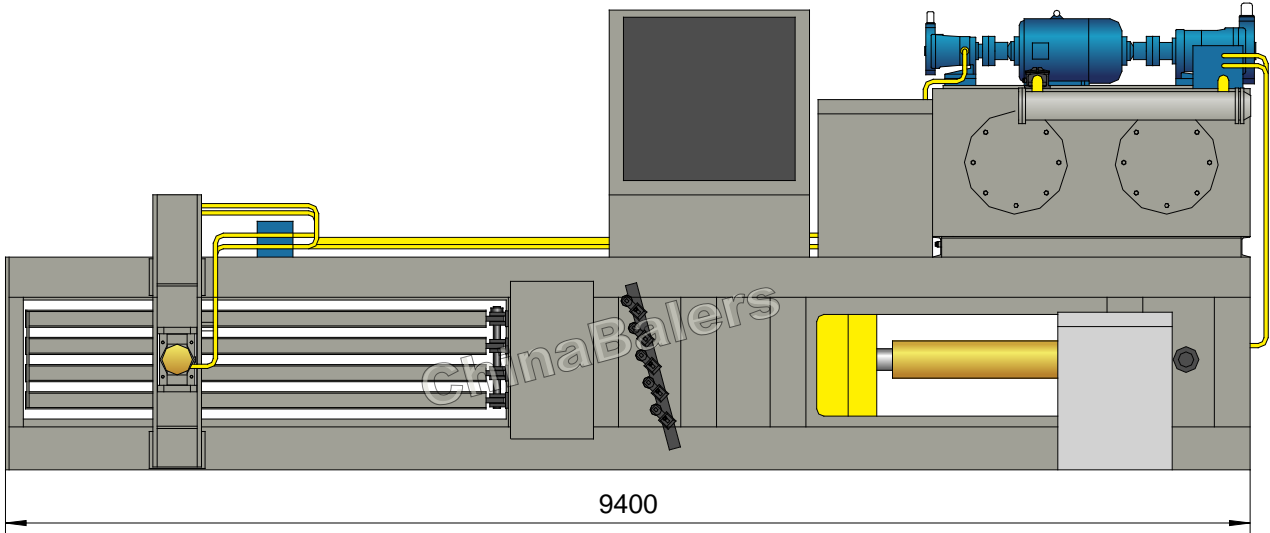

## Cardboard Baling Press

Model: HPA80A

### Power System (Main Motor)

Type:	Y280S-6
Rated Power:	45 kW
Rated Speed:	980 rpm
Power Spec:	3PH, 50 / 60Hz

### System Parameters

Main Pressure Cyl. Force:	80 Ton
Necking Cyl. Force:	3×50 Ton
Wire Pushing Cyl. Force:	8 Ton
Wire Cutting Cyl. Force:	8 Ton
Hydraulic System Pressure:	25 MPa

### Hydraulic System (Pump, 2 sets)

Pump #1:	250YCY14-1B
Rated Displacement:	250 ml/r
Max Operating Pressure:	31.5 MPa

Pump #2:	40YCY14-1B
Rated Displacement:	40 ml/r
Max Operating Pressure:	31.5 MPa

### Operation System

Mitsubishi / Siemens PLC & Touch Screen.

### Standard Configuration

NOK (JAPAN) Seal Packings for Cylinders;  
V-shaped Cutting Blades; Wire Frame; Oil Cooler;  
Conveyor Width 1400mm, Powered by 7.5kW Motor.

### Optional Configuration

Oil Heater; Magnetic Oil Filter;  
Siemens PLC S7-300 for Long Distance Data Transmission;  
Rexroth Pumps; Siemens Electrical Elements;  
Diesel / Diesel Generator for Power.

### General Description

Main Machine Size (L×W×H):	9400×4000×3600 mm
Feeding Opening (L×W):	1600×720 mm
Bale Size (W×H):	720×1100 mm
Bale Weight (Cardboard):	400-530 kg
Production Rate (Cardboard):	3.2-4.2 tons/hr
Strapping:	Tempered Iron Wire, $\phi$ 2.8/3.2mm, 5 Lines, Automatic Strapping.
Shipping Weight:	Approx. 21 + 6.5 tons
Loading (Standard Containers):	2×40'GP

### Hydraulic Oil Brand

Oil Tank Volume: 2100 ltr

ISO VG	China	U.S.		Britain	France
	GB11118.1	CALTEX CO.	MOBIL	SHELL	ELF CO.
HM 46	46 #	Rando HD46	D.T.E46	Tellus 46	Elfolna 46
HM 68	68 #	Rando HD68	D.T.E68	Tellus 68	Elfolna 68

Above information are indicative not engaging. Rights reserved for change if necessary.