

YE81T-250C

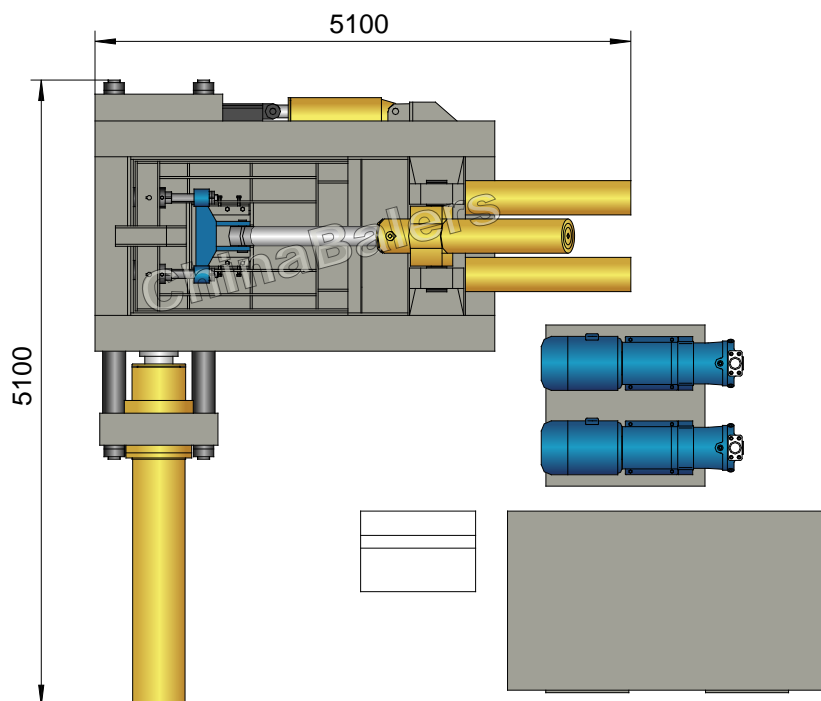

YE81T-250C

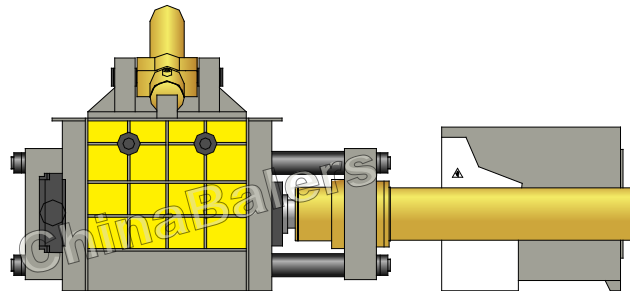
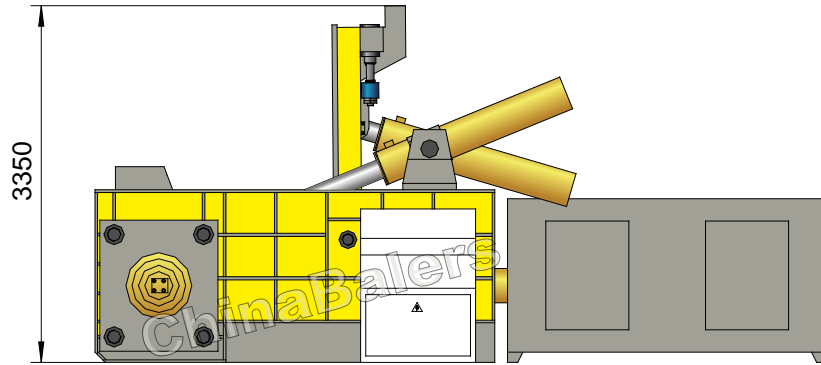

Car Scrap Compactor

Model: YE81T-250C

Power System (Motor, 2 sets)

Type:	Y200L-4
Rated Power:	30 kW (/set)
Rated Speed:	1470 rpm
Power Spec:	3PH, 50 / 60Hz

Hydraulic System (Pump, 2 sets)

Type:	HY125
Rated Displacement:	125 ml/r (/set)
Max Operating Pressure:	31.5 MPa

Standard Configuration

#45 Steel Liners 20mm, Wholly Heat Treated;
NOK (JAPAN) Seal Packings for Cylinders;
Cooler / Heater; Magnetic Oil Filter.

General Description

Main Machine Size (L×W×H):	5100×5100×3350 mm
Press Box Size (L×W×H):	2000×1400×1200 mm
Bale Size (W×H):	450×450 / 500×500 mm
Bale Weight (Steel):	250-450 kg
Production Rate (Steel):	4.5-7.0 tons/hr
Shipping Weight:	Approx. 28 tons
Loading (Standard Containers):	3×20'GP

System Parameters

Lid Cyl. Force:	80 Ton
Side Pressure Cyl. Force:	2×120 Ton
Main Pressure Cyl. Force:	250 Ton
Small Door Cyl. Force:	50 Ton
Hydraulic System Pressure:	25 MPa
Idle Cycle Time:	Approx. 120 Sec

Operation System (Optional)

Option 1: Manual Valve Operation
Option 2: PLC Operation

Optional Configuration

Cutting Blades & Teeth (2 sides); Loading Hopper;
Mn65 Steel Liners for High Pressure Chamber;
Diesel / Diesel Generator for Power.

Hydraulic Oil Brand

Oil Tank Volume: 2800 ltr

ISO VG	China	U.S.		Britain	France
		GB11118.1	CALTEX CO.	MOBIL	SHELL
HM 46	46 #	Rando HD46	D.T.E46	Tellus 46	Elfolna 46
HM 68	68 #	Rando HD68	D.T.E68	Tellus 68	Elfolna 68

Above information are indicative not engaging. Rights reserved for change if necessary.