

Y81T-250D

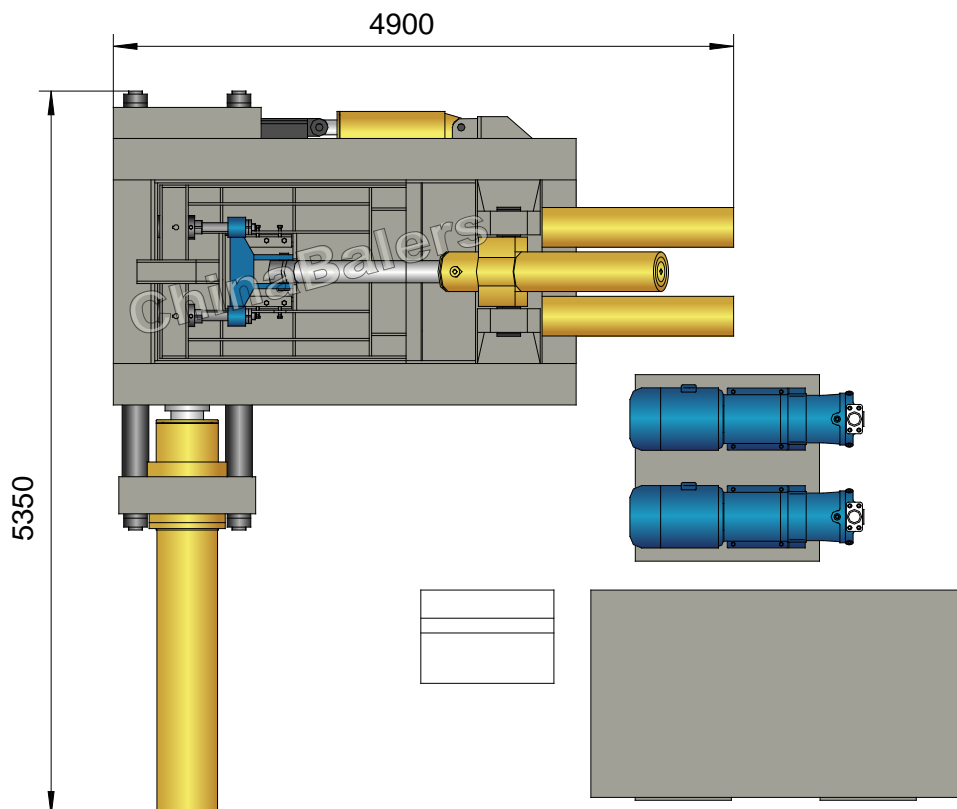

Y81T-250D

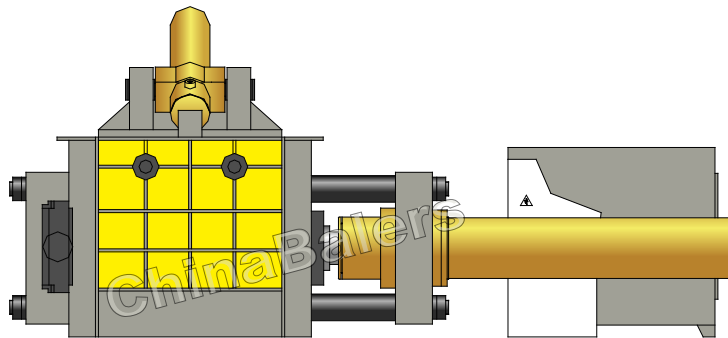
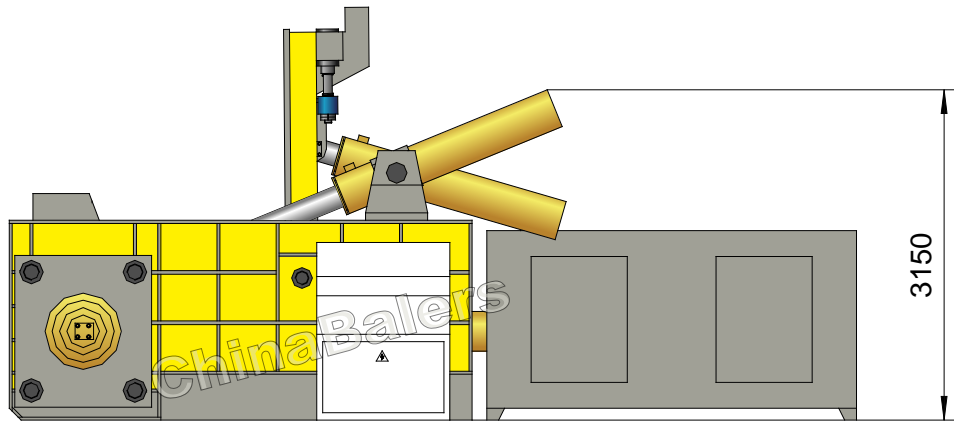

Car Baling Machine

Model: Y81T-250D

Power System (Motor, 2 sets)

Type:	Y225M-6
Rated Power:	30 kW (/set)
Rated Speed:	980 rpm
Power Spec:	3PH, 50 / 60Hz

Hydraulic System (Pump, 2 sets)

Type:	160YCY14-1B
Rated Displacement:	160 ml/r (/set)
Max Operating Pressure:	31.5 MPa

Operation System (Optional)

- Option 1: Manual Valve Operation
- Option 2: PLC Operation

System Parameters

Lid Cyl. Force:	80 Ton
Side Pressure Cyl. Force:	2×120 Ton
Main Pressure Cyl. Force:	250 Ton
Small Door Cyl. Force:	50 Ton
Hydraulic System Pressure:	25 MPa
Idle Cycle Time:	Approx. 140 Sec

Standard Configuration

A3 Steel Liners, Surface Heat Treatment.

Optional Configuration

- Cutting Blades & Teeth (2 sides);
- Loading Hopper; Cooler / Heater;
- Diesel / Diesel Generator for Power.

General Description

Main Machine Size (L×W×H):	4900×5350×3150 mm
Press Box Size (L×W×H):	2000×1750×1200 mm
Bale Size (W×H):	500×500 mm
Bale Weight (Steel):	250-450 kg
Production Rate (Steel):	4.5-7.0 tons/hr
Shipping Weight:	Approx. 27 tons
Loading (Standard Containers):	

Hydraulic Oil Brand

Oil Tank Volume:

2800 ltr

ISO VG	China	U.S.		Britain	France
	GB11118.1	CALTEX CO.	MOBIL	SHELL	ELF CO.
HM 46	46 #	Rando HD46	D.T.E46	Tellus 46	Elfolna 46
HM 68	68 #	Rando HD68	D.T.E68	Tellus 68	Elfolna 68

Above information are indicative not engaging. Rights reserved for change if necessary.