

HBB-125/6000

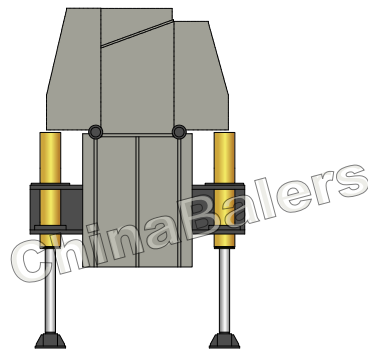

HBB-125/6000

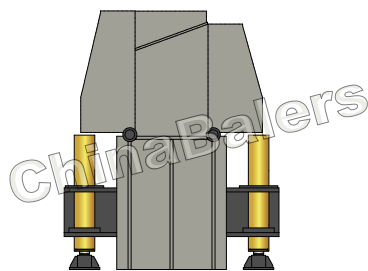
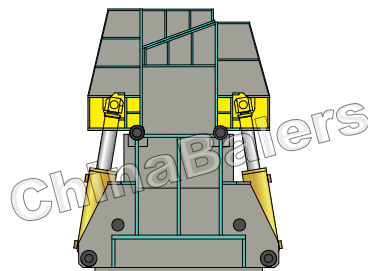
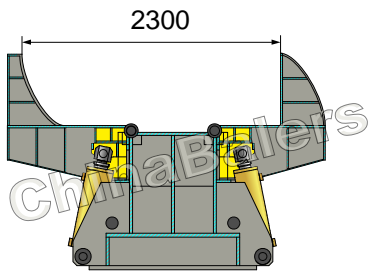
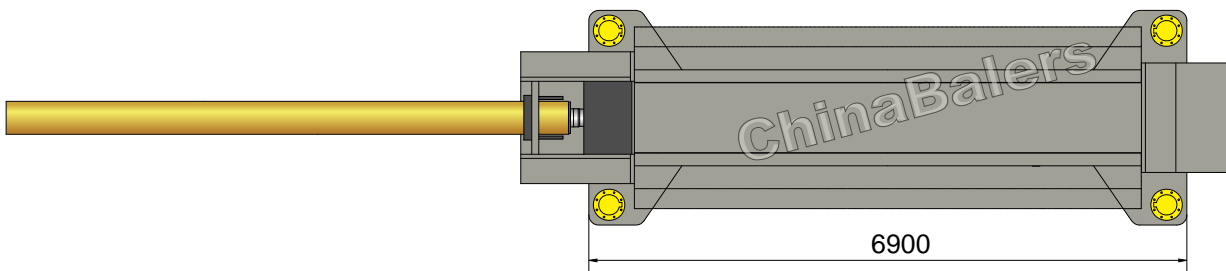
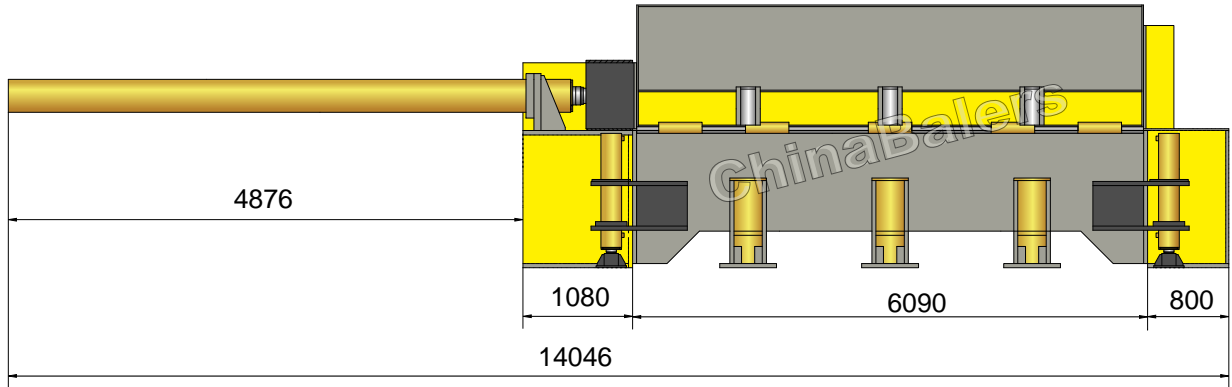

Car Baler

Model: HBB-125/6000

Power System (Diesel Engine, 1 set)

Diesel Type:	Cummins 6BT5.9-G2
Rated Speed:	1500 rpm
Output:	121 kW

Hydraulic System (Pump, 2 sets)

Type:	LY-A7V160
Rated Displacement:	160 ml/r (/set)
Max Operating Pressure:	35 MPa

Operation System

Siemens PLC & Remote Controller.

System Parameters

Wing Cyl. Force:	3×63 Ton
Lid Cyl. Force:	3×80 Ton
Main Pushing Cyl. Force:	125 Ton
Front Door Cyl. Force:	55 Ton
Lifting Cyl. Force:	4×55 Ton
Hydraulic System Pressure:	25 MPa

Standard Configuration

NOK (JAPAN) Seal Packings for Cylinders;
Oil Cooling & Filtering System; Tank Heater;
Long Distance Data Transmission.

General Description

Main Machine Size (L×W×H):	14100×2250×2590 mm
Feed Opening (L×W):	6000×2300 mm
Bale Size (W×H):	720×650 mm
Bale Weight (Whole Car):	400-700 kg
Production Rate (Cars):	10-15 cars per hour
Shipping Weight:	Approx. 30 tons
Loading (Standard Containers):	1×40'(HC)OT + 1×20'GP

Hydraulic Oil Brand

Oil Tank Volume: 3500 ltr

ISO VG	China	U.S.	Britain	France	
	GB11118.1	CALTEX CO.	MOBIL	SHELL	ELF CO.
HM 46	46 #	Rando HD46	D.T.E46	Tellus 46	Elfolna 46
HM 68	68 #	Rando HD68	D.T.E68	Tellus 68	Elfolna 68

Above information are indicative not engaging. Rights reserved for change if necessary.