

Y81Q-135B

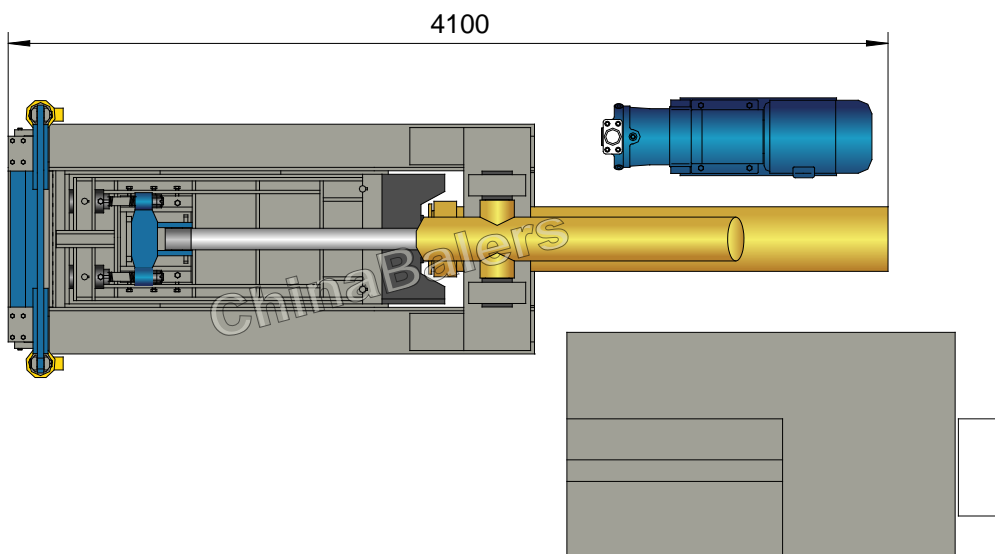

Y81Q-135B

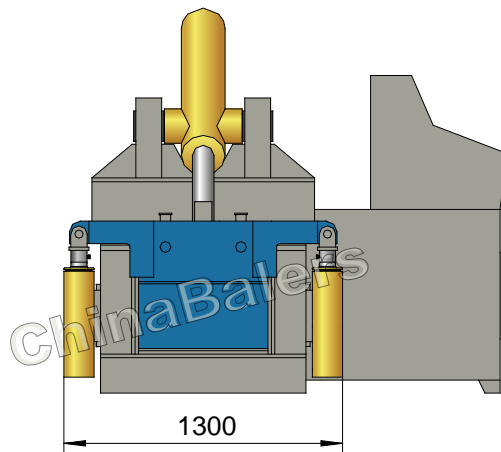
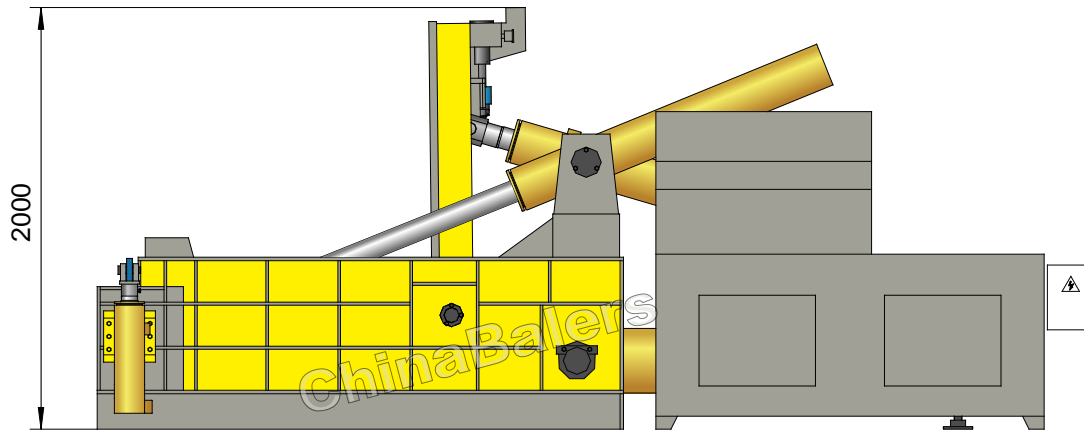
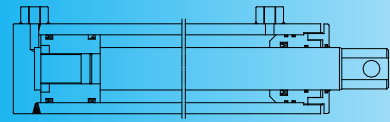
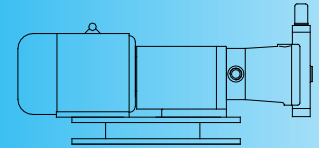

Can Compactor

Model: Y81Q-135B

Power System (Motor)

Type: Y200L2-6
 Rated Power: 22 kW
 Rated Speed: 970 rpm
 Power Spec: 3PH, 50 / 60Hz

System Parameters

Lid Cyl. Force: 50 Ton
 Main Pressure Cyl. Force: 135 Ton
 Front Door Cyl. Force: 2×24 Ton
 Hydraulic System Pressure: 25 MPa
 Idle Cycle Time: Approx. 70 Sec

Hydraulic System (Pump)

Type: 160YCY14-1B
 Rated Displacement: 160 ml/r
 Max Operating Pressure: 31.5 MPa

Standard Configuration

A3 Steel Liners, Surface Heat Treatment.

Operation System (Optional)

Option 1: Manual Valve Operation
 Option 2: PLC Operation

Optional Configuration

Cutting Blades & Teeth (2 sides);
 Cooler / Heater;
 Diesel / Diesel Generator for Power.

General Description

Main Machine Size (L×W×H): 4100×1300×2000 mm
 Press Box Size (L×W×H): 1300×600×600 mm
 Bale Size (W×H): 600×240 mm
 Bale Weight (Aluminum Can): 18-25 kg
 Production Rate (Aluminum Can): 0.4-0.6 tons/hr
 Shipping Weight: Approx. 6.6 tons
 Loading (Standard Containers):

Hydraulic Oil Brand

Oil Tank Volume: 1200 ltr

ISO VG	China	U.S.		Britain	France
	GB11118.1	CALTEX CO.	MOBIL	SHELL	ELF CO.
HM 46	46 #	Rando HD46	D.T.E46	Tellus 46	Elfolna 46
HM 68	68 #	Rando HD68	D.T.E68	Tellus 68	Elfolna 68

Above information are indicative not engaging. Rights reserved for change if necessary.