

YE83-315

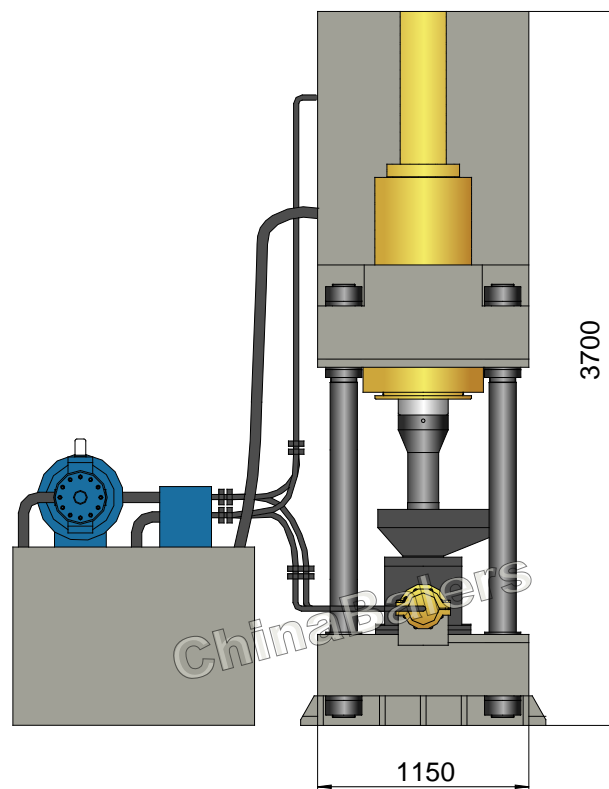

YE83-315

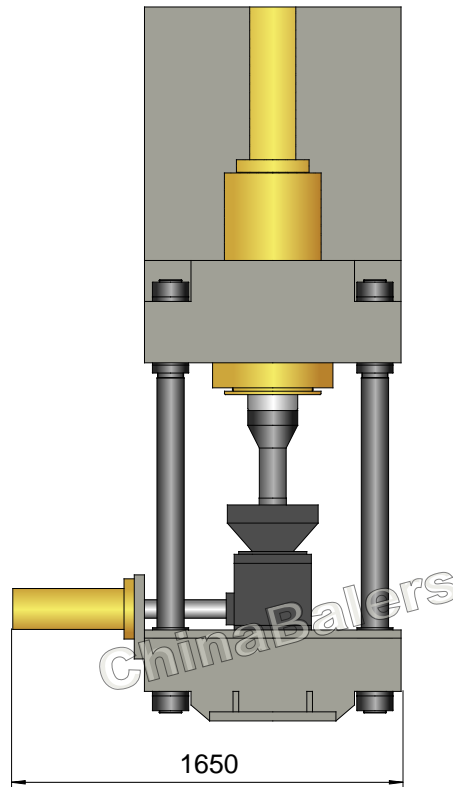

Briquetting Press

Model: YE83-315

Power System (Motor)

Type:	Y225M-6
Rated Power:	30 kW
Rated Speed:	980 rpm
Power Spec:	3PH, 50 / 60Hz

System Parameters

Main Cyl. Force:	285 Ton
Auxiliary Cyl. Force:	55 Ton
Discharging Cyl. Force:	30 Ton
Hydraulic System Pressure:	25 MPa
Idle Cycle Time:	12-15 Sec

Hydraulic System (Pump)

Type	160YCY14-1B
Rated Displacement:	160 ml/r
Max Operating Pressure:	31.5 MPa

Operation System

PLC Operation

Standard Configuration

NOK (JAPAN) Seal Packings for Cylinders;
Cooler / Heater; Magnetic Oil Filter.

Optional Configuration

Feeding Conveyor & Vibrating Motor;
Diesel / Diesel Generator for Power.

General Description

Main Machine Size (L×W×H):	1650×1150×3700 mm
Press Mould Size (Dia×H):	Φ120×300 mm
Pressure on Briquet:	278 MPa
Briquet Size (Dia×H):	Φ120×(70-100) mm
Briquet Weight (Cast Iron):	4.4-6.3 kg
Production Rate (Cast Iron):	1100-1200 kg/hr
Shipping Weight:	Approx. 9 tons
Loading (Standard Containers):	1×20'GP

Hydraulic Oil Brand

Oil Tank Volume: 2500 ltr

ISO VG	China	U.S.		Britain	France
	GB11118.1	CALTEX CO.	MOBIL	SHELL	ELF CO.
HM 46	46 #	Rando HD46	D.T.E46	Tellus 46	Elfolna 46
HM 68	68 #	Rando HD68	D.T.E68	Tellus 68	Elfolna 68

Above information are indicative not engaging. Rights reserved for change if necessary.