

HPA180

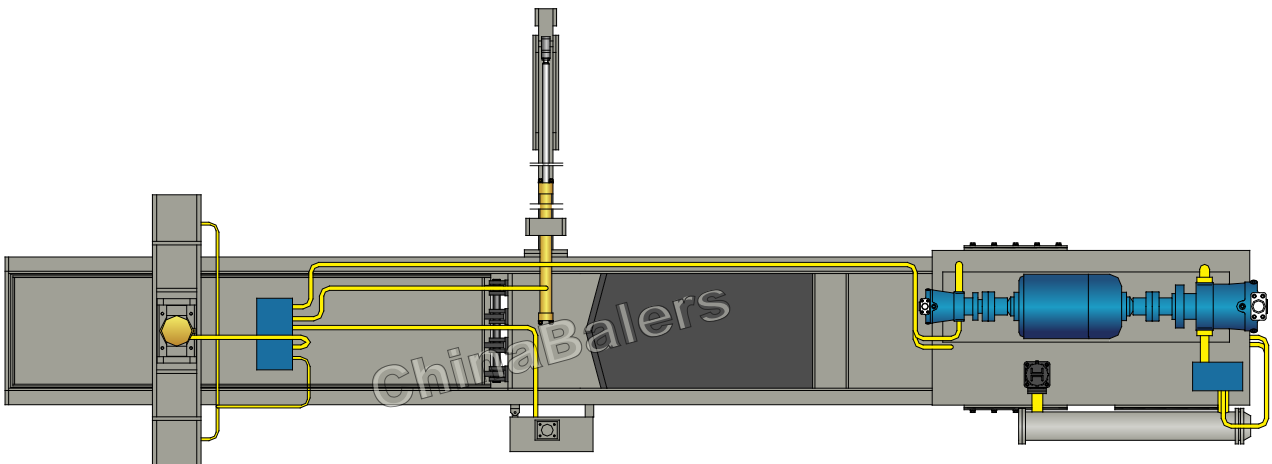

HPA180

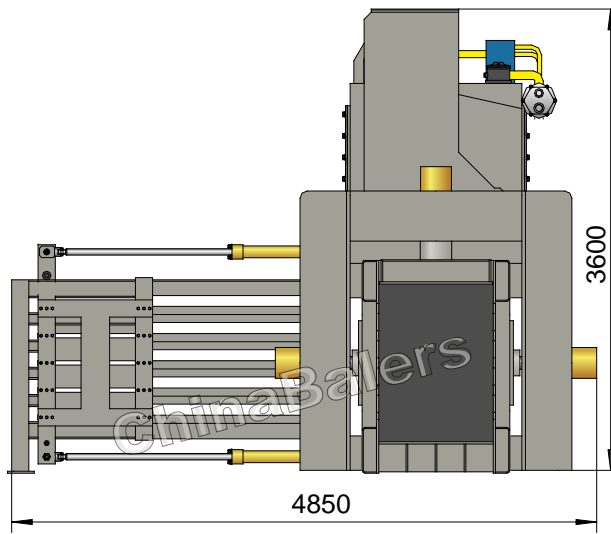
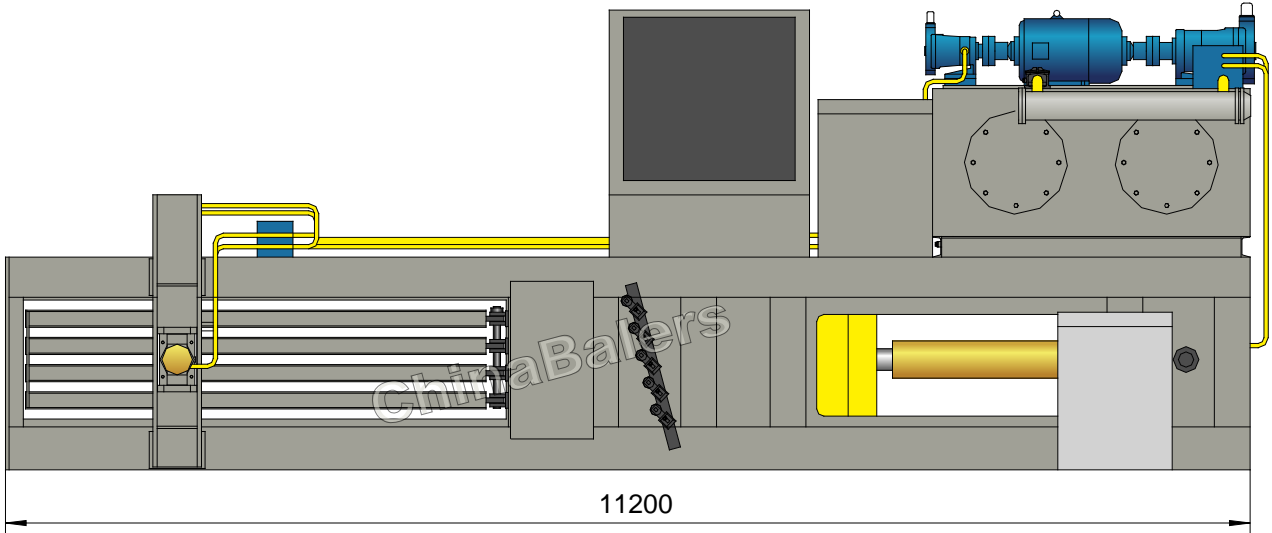

Automatic Cardboard Baler

Model: HPA180

Power System (Main Motor, 2 sets)

Type: Y315M-6
 Rated Power: 90 kW (/set)
 Rated Speed: 990 rpm
 Power Spec: 3PH, 50 / 60Hz

Hydraulic System (Pump, 4 sets)

Pump #1, #2, #3: 250YCY14-1B
 Rated Displacement: 250 ml/r (/set)
 Max Operating Pressure: 31.5 MPa

Pump #4: 40YCY14-1B
 Rated Displacement: 40 ml/r
 Max Operating Pressure: 31.5 MPa

Operation System

Mitsubishi / Siemens PLC & Touch Screen.

General Description

Main Machine Size (L×W×H): 11200×4850×3600 mm
 Feeding Opening (L×W): 2200×1100 mm
 Bale Size (W×H): 1100×1100 mm
 Bale Weight (Cardboard): 810-1350 kg
 Production Rate (Cardboard): 11.3-16.2 tons/hr
 Strapping: Tempered Iron Wire, ϕ 3.2/3.6mm, 5 Lines, Automatic Strapping.
 Shipping Weight: Approx. 29 + 7 tons
 Loading (Standard Containers): 2×40'GP

Hydraulic Oil Brand

Oil Tank Volume: 4900 ltr

ISO VG	China	U.S.		Britain	France
	GB11118.1	CALTEX CO.	MOBIL	SHELL	ELF CO.
HM 46	46 #	Rando HD46	D.T.E46	Tellus 46	Elfolna 46
HM 68	68 #	Rando HD68	D.T.E68	Tellus 68	Elfolna 68

System Parameters

Main Pressure Cyl. Force: 180 Ton
 Necking Cyl. Force: 3×80 Ton
 Wire Pushing Cyl. Force: 8 Ton
 Wire Cutting Cyl. Force: 8 Ton
 Hydraulic System Pressure: 25 MPa

Standard Configuration

NOK (JAPAN) Seal Packings for Cylinders;
 V-shaped Cutting Blades; Wire Frame; Oil Cooler;
 Conveyor Width 1600mm, Powered by 7.5kW Motor.

Optional Configuration

Oil Heater; Magnetic Oil Filter;
 Siemens PLC S7-300 for Long Distance Data Transmission;
 Rexroth Pumps; Siemens Electrical Elements;
 Diesel / Diesel Generator for Power.