

HPA50

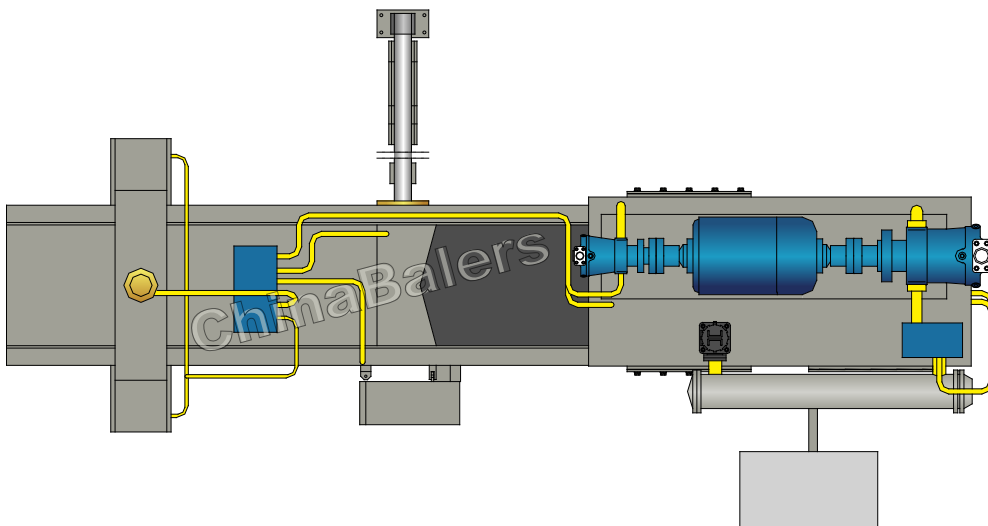

HPA50

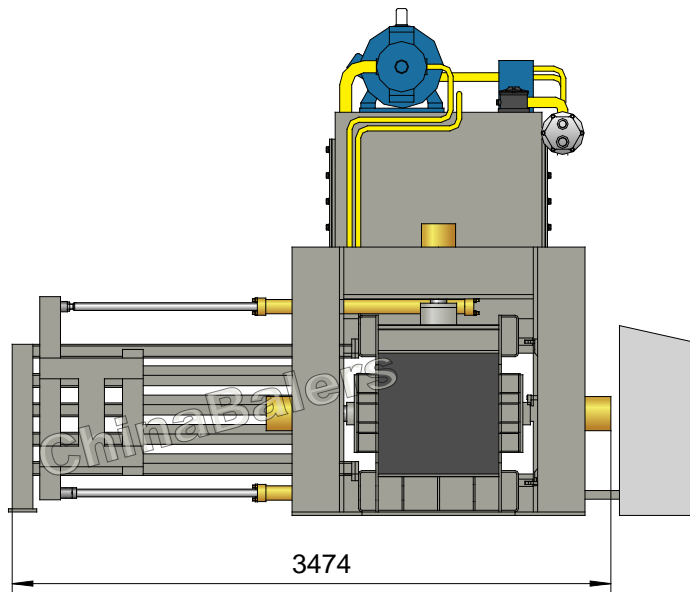
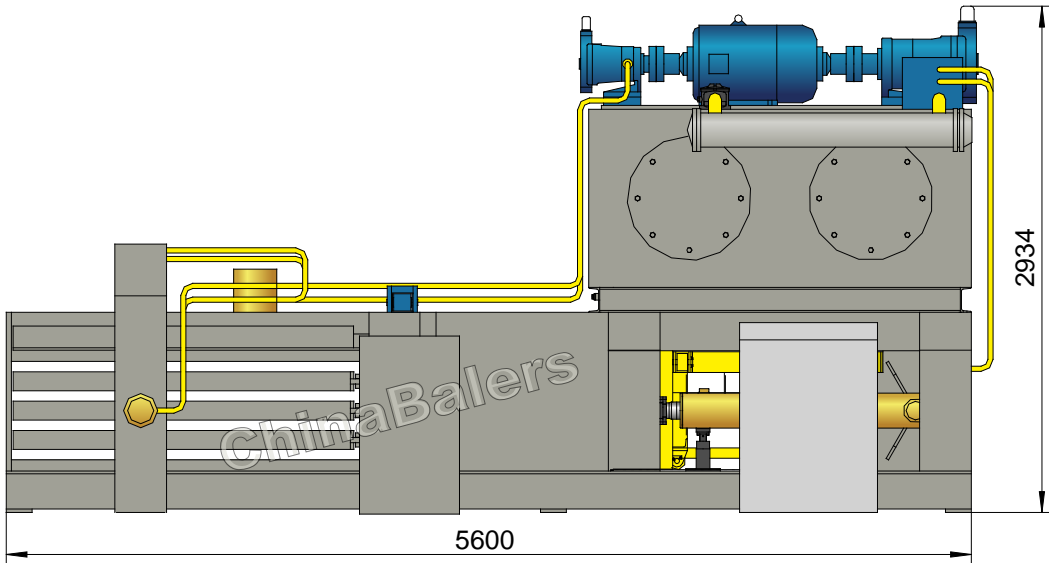

Automatic PET Baler

Model: HPA50

Power System (Main Motor)

Type:	Y200L2-6
Rated Power:	22 kW
Rated Speed:	970 rpm
Power Spec:	3PH, 50 / 60Hz

System Parameters

Main Pressure Cyl. Force:	50 Ton
Necking Cyl. Force:	3×30 Ton
Wire Pushing Cyl. Force:	8 Ton
Wire Cutting Cyl. Force:	8 Ton
Hydraulic System Pressure:	25 MPa

Hydraulic System (Pump, 2 sets)

Pump #1:	160YCY14-1B
Rated Displacement:	160 ml/r
Max Operating Pressure:	31.5 MPa

Pump #2:	40YCY14-1B
Rated Displacement:	40 ml/r
Max Operating Pressure:	31.5 MPa

Operation System

Mitsubishi / Siemens PLC & Touch Screen.

Standard Configuration

NOK (JAPAN) Seal Packings for Cylinders;
V-shaped Cutting Blades; Wire Frame; Oil Cooler;
Air Duct for Feeding (Prepared by Customer).

Optional Configuration

Oil Heater; Magnetic Oil Filter;
Siemens PLC S7-300 for Long Distance Data Transmission;
Rexroth Pumps; Siemens Electrical Elements;
Diesel / Diesel Generator for Power.

General Description

Main Machine Size (L×W×H):	5700×3500×3000 mm
Feeding Opening (L×W):	900×700 mm
Bale Size (W×H):	700×700 mm
Bale Weight (PET Bottle):	200-230 kg
Production Rate (PET Bottle):	0.9-1.0 tons/hr
Strapping:	Tempered Iron Wire, ϕ 2.8/3.2mm, 4 Lines, Automatic Strapping.
Shipping Weight:	Approx. 12 tons
Loading (Standard Containers):	1×40'GP

Hydraulic Oil Brand

Oil Tank Volume: 1100 ltr

ISO VG	China	U.S.		Britain	France
	GB11118.1	CALTEX CO.	MOBIL	SHELL	ELF CO.
HM 46	46 #	Rando HD46	D.T.E46	Tellus 46	Elfolna 46
HM 68	68 #	Rando HD68	D.T.E68	Tellus 68	Elfolna 68

Above information are indicative not engaging. Rights reserved for change if necessary.