

# YE81T-125B

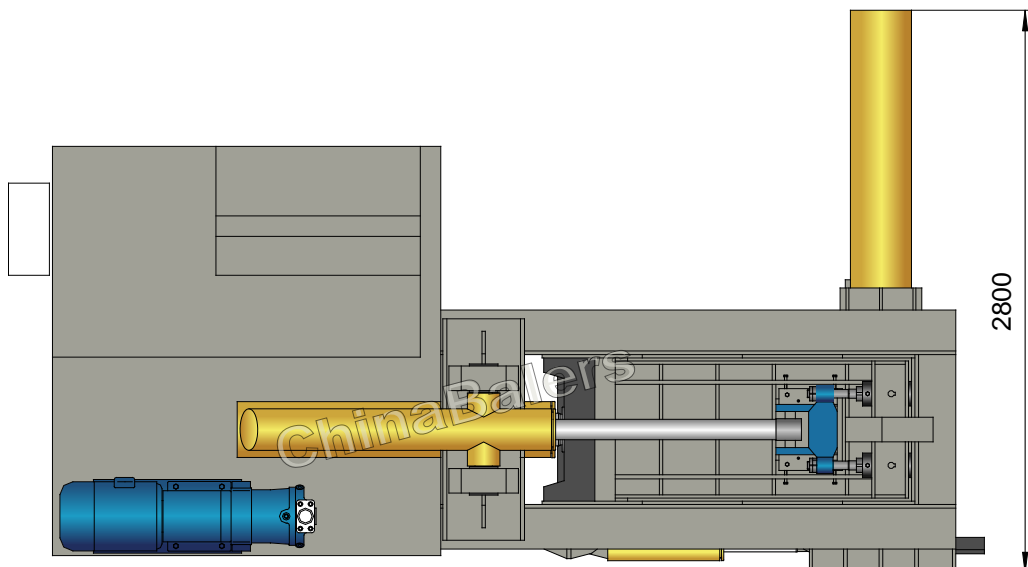

# YE81T-125B

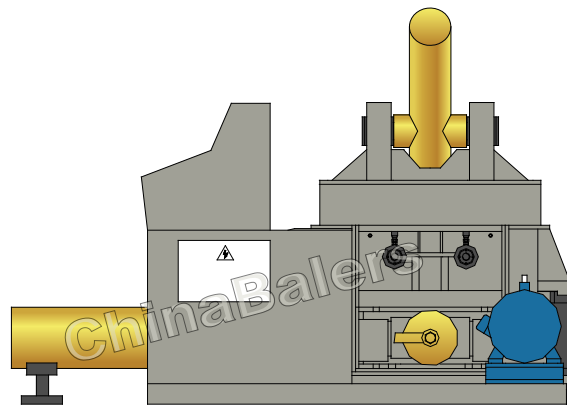
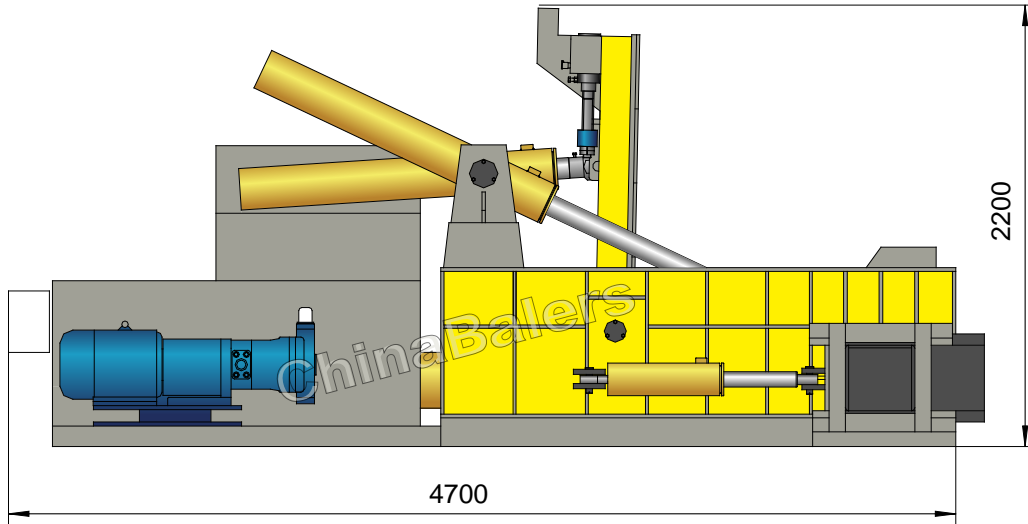

## Aluminum Turnings Baler

Model: YE81T-125B

### Power System (Motor)

Type:	Y180M-4 / Y200L2-6
Rated Power:	18.5 / 22 kW
Rated Speed:	1470 / 970 rpm
Power Spec:	3PH, 50 / 60Hz

### Hydraulic System (Pump)

Type:	80YCY / 160YCY
Rated Displacement:	80 / 160 ml/r
Max Operating Pressure:	31.5 MPa

### Standard Configuration

#45 Steel Liners 18mm, Wholly Heat Treated;  
NOK (JAPAN) Seal Packings for Cylinders;  
Cooler / Heater; Magnetic Oil Filter.

### System Parameters

Lid Cyl. Force:	50 Ton
Side Pressure Cyl. Force:	100 Ton
Main Pressure Cyl. Force:	125 Ton
Small Door Cyl. Force:	32 Ton
Hydraulic System Pressure:	25 MPa
Idle Cycle Time:	Approx. 100 / 80 Sec

### Operation System (Optional)

Option 1: Manual Valve Operation  
Option 2: PLC Operation

### Optional Configuration

Cutting Blades & Teeth (2 sides); Loading Hopper;  
Mn65 Steel Liners for High Pressure Chamber;  
Diesel / Diesel Generator for Power.

### General Description

Main Machine Size (L×W×H):	4700×2800×2200 mm
Press Box Size (L×W×H):	1400×700×700 mm
Bale Size (W×H):	300×300 mm
Bale Weight (Aluminum Turnings):	Approx. 20 kg
Production Rate (Aluminum Turnings):	Approx. 0.4 tons/hr
Shipping Weight:	Approx. 8 tons
Loading (Standard Containers):	1×20'GP

### Hydraulic Oil Brand

Oil Tank Volume: 1200 ltr

ISO VG	China	U.S.		Britain	France
	GB11118.1	CALTEX CO.	MOBIL	SHELL	ELF CO.
HM 46	46 #	Rando HD46	D.T.E46	Tellus 46	Elfolna 46
HM 68	68 #	Rando HD68	D.T.E68	Tellus 68	Elfolna 68

Above information are indicative not engaging. Rights reserved for change if necessary.