

YE83-400W

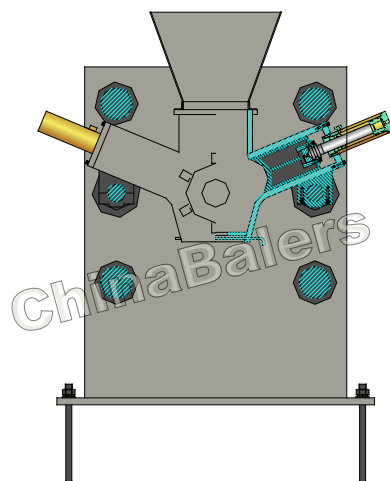

YE83-400W

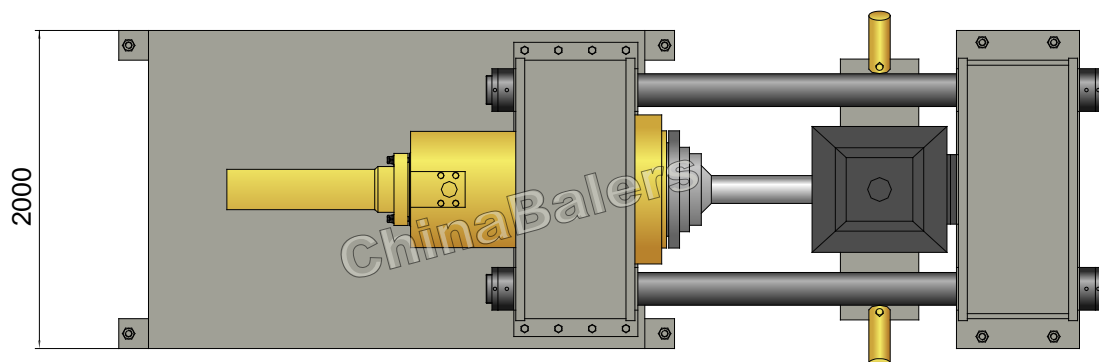
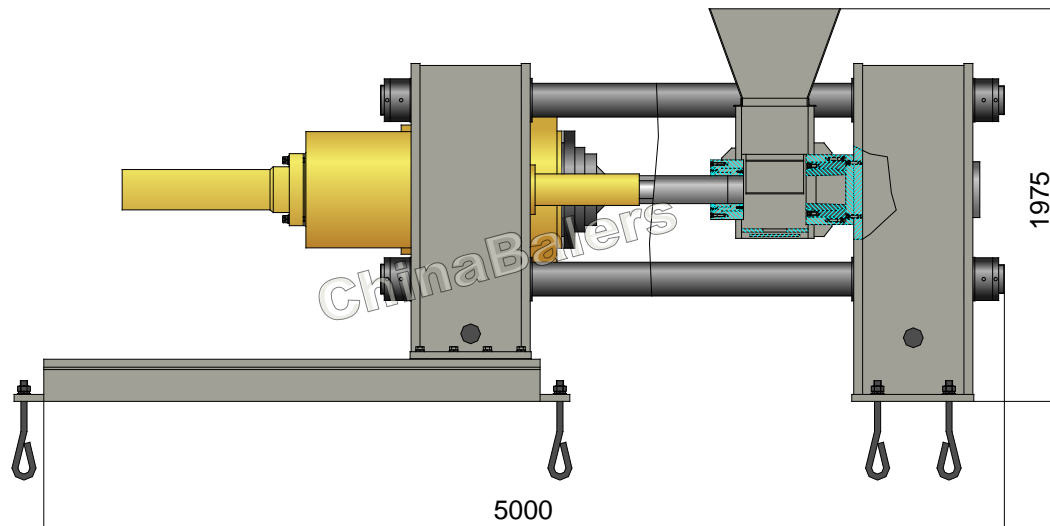

Aluminum Briquetting Machine

Model: YE83-400W

Power System (Motor, 3 sets)

Type:	Y180L-4
Rated Power:	22 kW (/set)
Rated Speed:	1470 rpm
Power Spec:	3PH, 50 / 60Hz

Hydraulic System (Pump, 3 sets)

Pump #1:	63YCY14-1B
Rated Displacement:	63 ml/r (/set)
Max Operating Pressure:	31.5 MPa

Standard Configuration

NOK (JAPAN) Seal Packings for Cylinders;
Cooler / Heater; Magnetic Oil Filter.

General Description

Main Machine Size (L×W×H):	5000×2000×1800 mm
Press Mould Size (Dia×H):	Φ140×(300+200) mm
Pressure on Briquet:	260 MPa
Briquet Size (Dia×H):	Φ140×(70-100) mm
Briquet Weight (Aluminum Chips):	2.7-4.0 kg
Production Rate (Aluminum Chips):	600-1000 kg/hr
Shipping Weight:	Approx. 16 tons
Loading (Standard Containers):	1×40'GP

System Parameters

Main Cyl. Force:	345 Ton
Auxiliary Cyl. Force:	55 Ton
Pre-compression Cyl. Force:	12 Ton
Discharging Cyl. Force:	15 Ton
Hydraulic System Pressure:	25 MPa
Idle Cycle Time:	12-15 Sec

Operation System

PLC Operation

Optional Configuration

Feeding Conveyor & Vibrating Motor;
Diesel / Diesel Generator for Power.

Hydraulic Oil Brand

Oil Tank Volume: 2500 ltr

ISO VG	China	U.S.		Britain	France
	GB11118.1	CALTEX CO.	MOBIL	SHELL	ELF CO.
HM 46	46 #	Rando HD46	D.T.E46	Tellus 46	Elfolna 46
HM 68	68 #	Rando HD68	D.T.E68	Tellus 68	Elfolna 68

Above information are indicative not engaging. Rights reserved for change if necessary.