

Y81T-160A

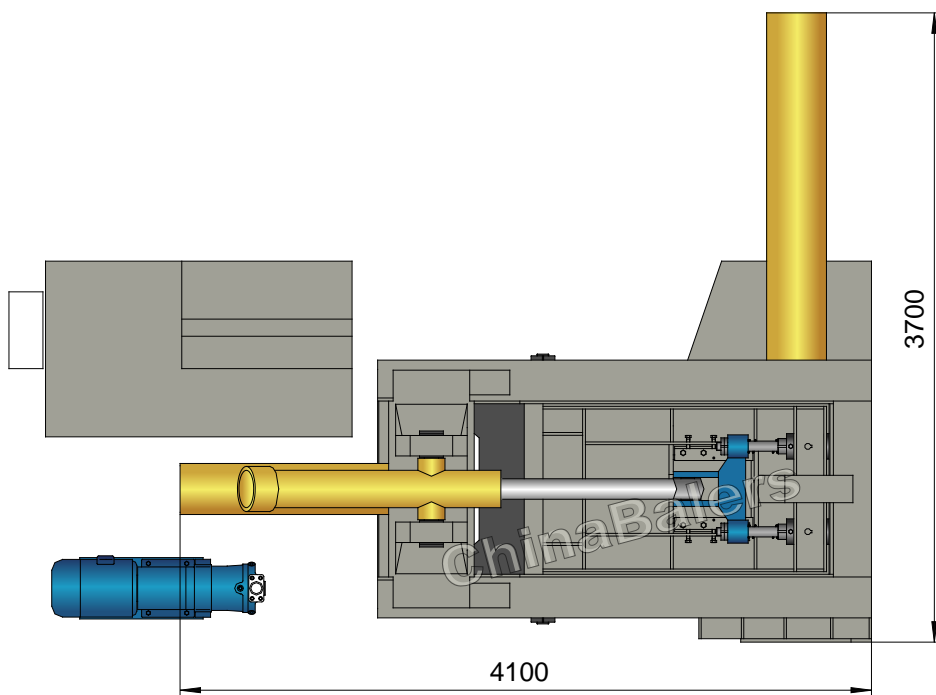

Y81T-160A

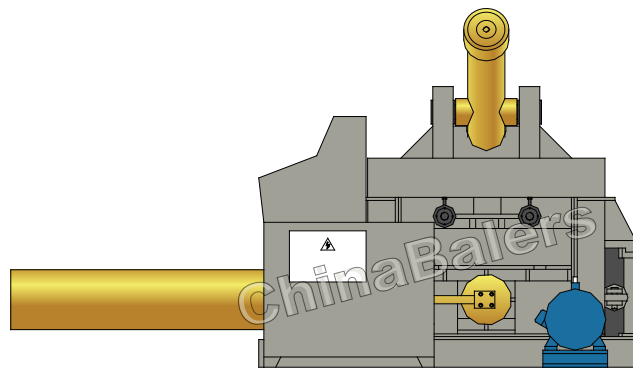
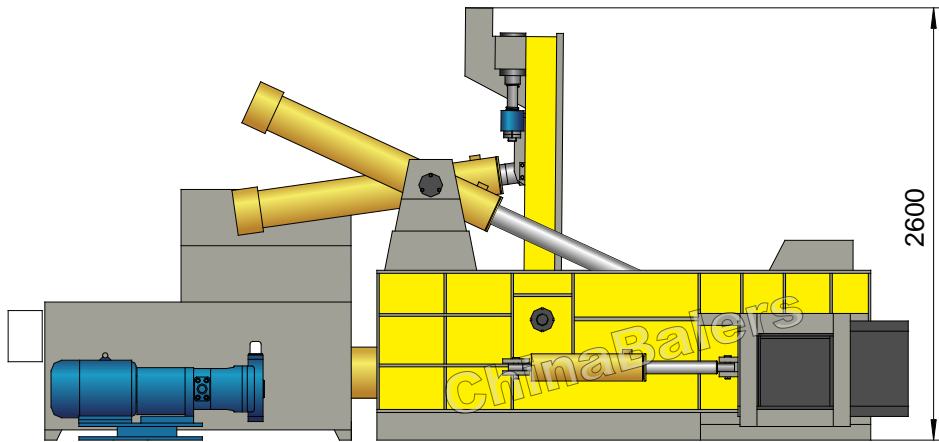
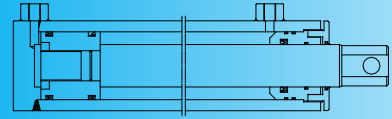
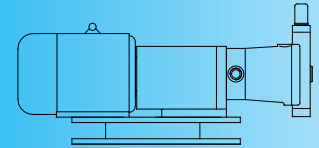

Alu Can Compactor

Model: Y81T-160A

Power System (Motor)

Type:	Y200L2-6
Rated Power:	22 kW
Rated Speed:	970 rpm
Power Spec:	3PH, 50 / 60Hz

Hydraulic System (Pump)

Type:	160YCY14-1B
Rated Displacement:	160 ml/r
Max Operating Pressure:	31.5 MPa

Operation System (Optional)

- Option 1: Manual Valve Operation
- Option 2: PLC Operation

System Parameters

Lid Cyl. Force:	63 Ton
Side Pressure Cyl. Force:	125 Ton
Main Pressure Cyl. Force:	160 Ton
Small Door Cyl. Force:	32 Ton
Hydraulic System Pressure:	25 MPa
Idle Cycle Time:	Approx. 110 Sec

Standard Configuration

A3 Steel Liners, Surface Heat Treatment.

Optional Configuration

- Cutting Blades & Teeth (2 sides);
- Loading Hopper; Cooler / Heater;
- Diesel / Diesel Generator for Power.

General Description

Main Machine Size (L×W×H):	4100×3700×2600 mm
Press Box Size (L×W×H):	1600×1000×800 mm
Bale Size (W×H):	350×350 / 400×400 mm
Bale Weight (Aluminum Can):	35-60 kg
Production Rate (Aluminum Can):	0.7-1.2 tons/hr
Shipping Weight:	Approx. 11.8 tons
Loading (Standard Containers):	

Hydraulic Oil Brand

Oil Tank Volume: 1200 ltr

ISO VG	China	U.S.		Britain	France
	GB11118.1	CALTEX CO.	MOBIL	SHELL	ELF CO.
HM 46	46 #	Rando HD46	D.T.E46	Tellus 46	Elfolna 46
HM 68	68 #	Rando HD68	D.T.E68	Tellus 68	Elfolna 68

Above information are indicative not engaging. Rights reserved for change if necessary.