

HPA125A

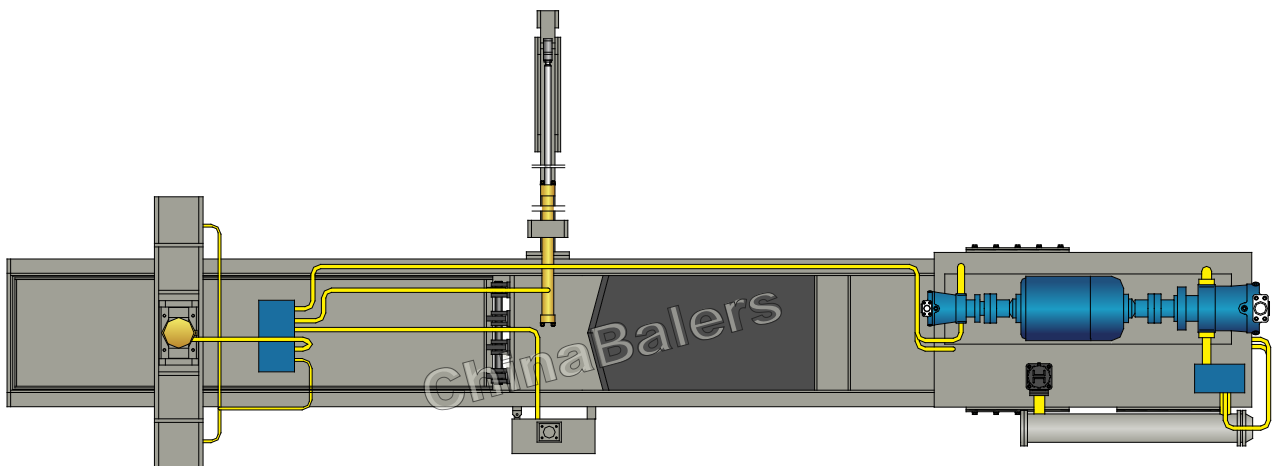

HPA125A

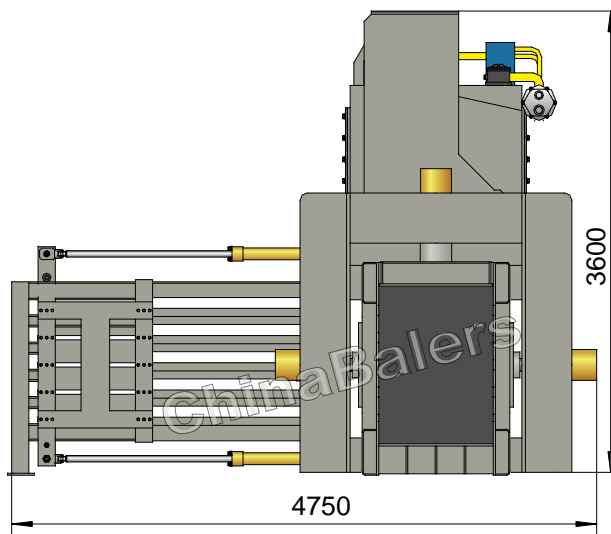
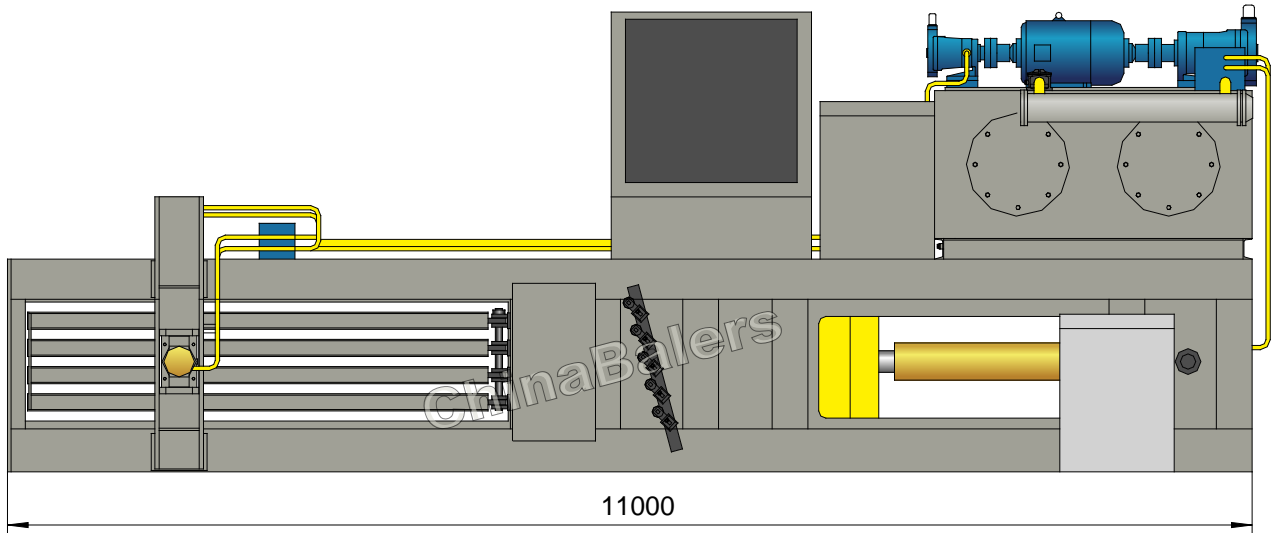

PET Bottle Compactor

Model: HPA125A

Power System (Main Motor, 2 sets)

Type: Y225S-4
Rated Power: 37 kW (/set)
Rated Speed: 1480 rpm
Power Spec: 3PH, 50 / 60Hz

System Parameters

Main Pressure Cyl. Force: 125 Ton
Necking Cyl. Force: 3×80 Ton
Wire Pushing Cyl. Force: 8 Ton
Wire Cutting Cyl. Force: 8 Ton
Hydraulic System Pressure: 25 MPa

Hydraulic System (Pump, 3 sets)

Pump #1, #2: 160YCY14-1B
Rated Displacement: 160 ml/r (/set)
Max Operating Pressure: 31.5 MPa

Pump #3: 40YCY14-1B
Rated Displacement: 40 ml/r
Max Operating Pressure: 31.5 MPa

Standard Configuration

NOK (JAPAN) Seal Packings for Cylinders;
V-shaped Cutting Blades; Wire Frame; Oil Cooler;
Conveyor Width 1600mm, Powered by 7.5kW Motor.

Operation System

Mitsubishi / Siemens PLC & Touch Screen.

Optional Configuration

Oil Heater; Magnetic Oil Filter;
Siemens PLC S7-300 for Long Distance Data Transmission;
Rexroth Pumps; Siemens Electrical Elements;
Diesel / Diesel Generator for Power.

General Description

Main Machine Size (L×W×H): 11000×4750×3600 mm
Feeding Opening (L×W): 2200×1100 mm
Bale Size (W×H): 1100×1100 mm
Bale Weight (PET Bottle): 580-770 kg
Production Rate (PET Bottle): 2.6-3.5 tons/hr
Strapping: Tempered Iron Wire, ϕ 3.2/3.6mm, 5 Lines, Automatic Strapping.
Shipping Weight: Approx. 23.5+7 tons
Loading (Standard Containers): 2×40'GP

Hydraulic Oil Brand

Oil Tank Volume: 2600 ltr

ISO VG	China	U.S.		Britain	France
	GB11118.1	CALTEX CO.	MOBIL	SHELL	ELF CO.
HM 46	46 #	Rando HD46	D.T.E46	Tellus 46	Elfolna 46
HM 68	68 #	Rando HD68	D.T.E68	Tellus 68	Elfolna 68

Above information are indicative not engaging. Rights reserved for change if necessary.