

HPM100A

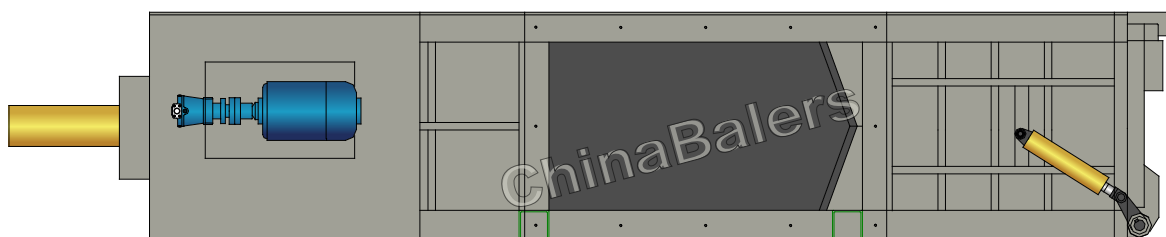

HPM100A

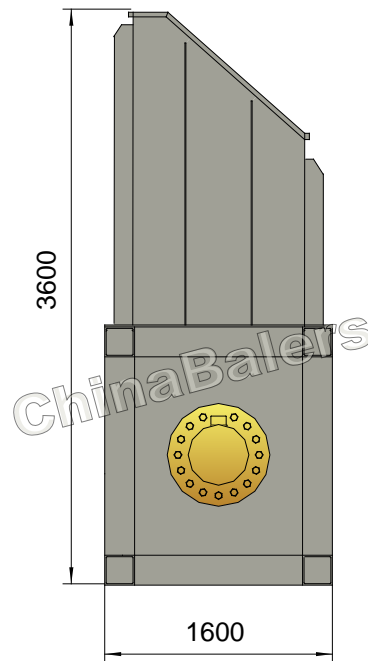
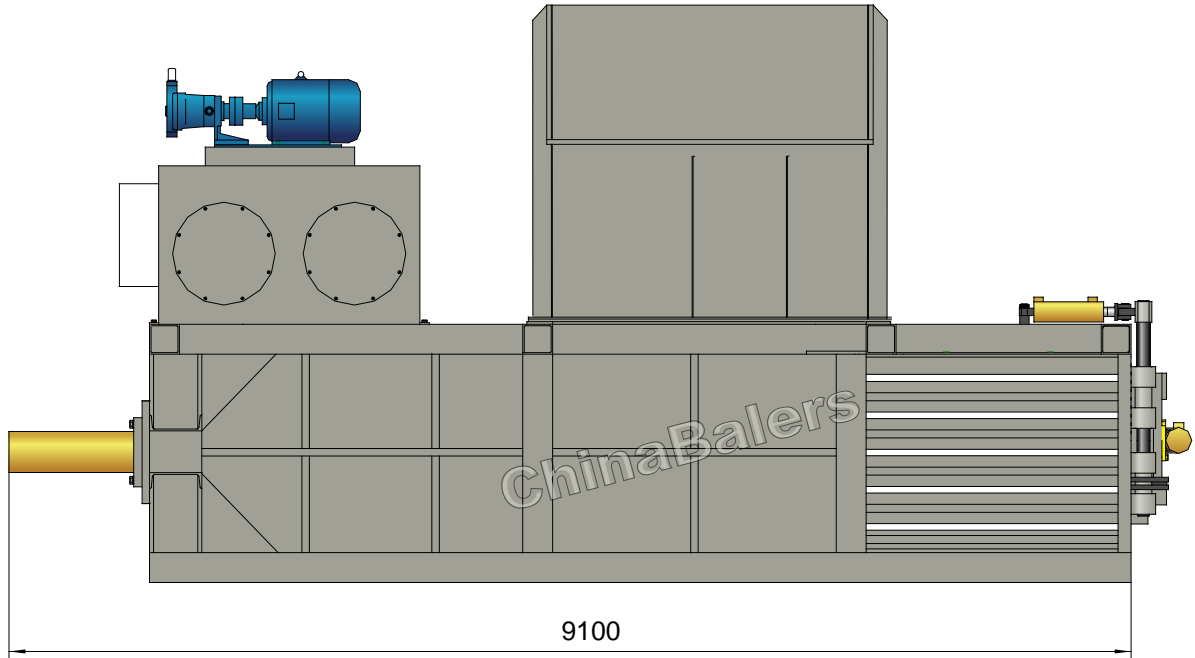

PET Bottle Baler

Model: HPM100A

Power System (Main Motor)

Type: Y225M-6
 Rated Power: 30 kW
 Rated Speed: 980 rpm
 Power Spec: 3PH, 50 / 60Hz

System Parameters

Main Pressure Cyl. Force: 100 Ton
 Locking Cyl. Force: 23.5 Ton
 Open-door Cyl. Force: 12.5 Ton
 Hydraulic System Pressure: 25 MPa

Hydraulic System (Pump, 2 sets)

Pump #1: 160YCY14-1B
 Rated Displacement: 160 ml/r
 Max Operating Pressure: 31.5 MPa

Pump #2: 25YCY14-1B
 Rated Displacement: 25 ml/r
 Max Operating Pressure: 31.5 MPa

Standard Configuration

V-shaped Cutting Blades; Oil Cooler;
 Conveyor Width 1400mm, Powered by 7.5kW Motor;
 Discharging Roll Powered by 0.75kW Motor.

Optional Configuration

NOK (JAPAN) Seal Packings for Cylinders;
 Oil Heater; Magnetic Oil Filter;
 Diesel / Diesel Generator for Power.

Operation System

PLC Operation

General Description

Main Machine Size (L×W×H): 9100×1600×3600 mm
 Feeding Opening (L×W): 2000×900 mm
 Bale Size (W×H): 900×900 mm
 Bale Weight (PET Bottle): 420-480 kg
 Production Rate (PET Bottle): 1.5-1.7 tons/hr
 Strapping: Tempered Iron Wire, ϕ 2.8/3.2mm, 4 Lines, Manual Strapping.
 Shipping Weight: Approx. 12.5 + 6.5 tons
 Loading (Standard Containers): 2×40'GP

Hydraulic Oil Brand

Oil Tank Volume: 1500 ltr

ISO VG	China	U.S.		Britain	France
	GB11118.1	CALTEX CO.	MOBIL	SHELL	ELF CO.
HM 46	46 #	Rando HD46	D.T.E46	Tellus 46	Elfolna 46
HM 68	68 #	Rando HD68	D.T.E68	Tellus 68	Elfolna 68

Above information are indicative not engaging. Rights reserved for change if necessary.